

GENERATION 6



EnviroStart™ Three Phase Motor Energy Controller Installation & Commissioning Guide

Version 2.13 June 2010



2.2kW through 800kW

Three Phase EnviroStart™ Motor Energy Control

IMPORTANT WARNING

Failure to read and comply with this manual may result in damage to the EnviroStart Unit and driven equipment and may render the warranty invalid.

1. Only a competent electrician should carry out the electrical installation.
2. EnviroStart must be earthed with an earthing conductor connected to the earthing terminal.
3. Before installation check the motor rating plate and Section Two of this manual to ensure that the EnviroStart is correctly rated for the application.
4. Internal components and areas of the control circuit boards, (except the isolated I/O terminals), can be at mains potential when the EnviroStart is connected to a three-phase supply. The voltage is extremely dangerous and may cause death or severe injury if you come into contact with it.
5. When the EnviroStart is connected to the mains, the motor connections U, V and W should be treated as being live even if the motor is not running.
6. The control I/O terminals are isolated from mains potential but the relay outputs may have dangerous voltages present even if the mains are not connected.
7. Do not make any connections when the EnviroStart is connected to live mains.
8. Do not make voltage withstand tests on any part of the EnviroStart without isolating the unit.
9. Do not touch IC-circuits on the PCB. Certain items are static-sensitive and static voltage discharge may destroy the components.
10. Make sure no power-factor correction capacitors are connected to the motor cable except in a safe manner. (See body text of this document for details).
11. Make sure the cover is closed before applying mains voltage to the EnviroStart.
12. Updated and current Installation and Commissioning Guides are maintained on the EMS (European) web site at <http://www.EnviroStart.com>; always check the web site for latest issue documents before commencing installation.
13. The chipset used in the Generation 6 series are NOT compatible with previous generation PCB's though previous chip sets from Generation 5 systems, (TPMEC Series), will operate in the Generation 6 PCB's. The interchange of chipsets between TPMEC and TPMECG6 PCB's is not recommended and should only be undertaken when no other options are available. (If such a transposition is done then switch settings 1.1 through 2.8 equate to switches 1 through 16 per the TPMEC Installation Guide. Energy Saving Mode on Link 1 on the TPMEC PCB is now enabled on switch 20, the OFF position enabling Energy Saving, the ON position disabling Energy Saving).

CONTENTS

1	INTRODUCTION	5
1.1	FEATURES	5
2	RATING INFORMATION	6
2.1	CORRECT ENVIROSTART SIZING.....	6
2.2	RATING: 220V/400V, 208V/480V, 570V & 690V SYSTEMS	6
2.3	CE DECLARATION OF CONFORMITY	7
3	SPECIFICATION	8
3.1	TECHNICAL SPECIFICATIONS.....	8
3.2	HIGH SPEED FUSES - (55kW - 800kW)).....	10
3.3	HARMONICS	10
3.4	HEAT LOSSES	10
3.5	HEAT DISSIPATION.....	10
3.6	SELECTING A FAN	11
3.7	CONTROL PANELS WITH MULTIPLE ENVIROSTART	11
3.8	COOLING FAN POSITION	11
3.9	CABINET COOLING FANS	11
3.10	POWER LOSSES	12
4	INSTALLATION	13
4.1	IMMUNITY FROM INTERFERENCE.....	13
4.2	COIL SUPPRESSION.....	13
4.3	LIGHTNING STRIKES / VERY HIGH VOLTAGE TRANSIENTS	13
4.4	CONTROL VOLTAGE TRANSIENTS.....	13
4.5	INPUT / OUTPUT CONTROL CONNECTIONS	13
4.6	EMISSIONS	13
4.7	BY-PASS CONTACTOR.....	13
4.8	VENTILATION.....	13
4.9	COS PHI CORRECTION (PFC).....	14
4.10	BURDEN RESISTOR SETTINGS	14
4.11	SLIP RING MOTORS.....	15
4.12	LOAD SIZING.....	16
4.13	CABLE AND INPUT FUSE RATINGS	16
4.14	BUS BARS	16
	CONNECTION	17
4.15	TERMINAL FUNCTION AND LOCATION	17
4.16	MAINS CONNECTION SCHEMATIC DRAWING.....	19
4.17	CONTROL CONNECTIONS UTILISING ALL FEATURES.....	20
4.18	CONTROL CONNECTIONS MINIMUM REQUIREMENTS.....	20
4.19	CONTROL CONNECTIONS – AUTOMATIC START/EMERGENCY RUN.....	21
4.20	CONTROL CONNECTIONS AUTOMATIC START	21

4.21	STAR DELTA CONNECTION	22
	COMMISSIONING	22
4.22	PRE-COMMISSIONING CHECKS.....	22
4.23	COMMISSIONING INSTRUCTIONS	22
4.24	SETTING FEATURES.....	23
4.25	USER ADJUSTMENTS MAP.....	24
5	USER CONTROL FEATURES	27
5.1	DEFAULT SETTINGS.....	27
5.2	RAMP UP TIME SETTING.....	29
5.3	RAMP UP & RAMP DOWN TIME MULTIPLIER.....	29
5.4	ENERGY REDUCTION LEVEL SETTINGS	29
5.5	THYRISTOR FAULT DETECTION	30
5.6	START-UP PEDESTAL VOLTAGE SETTINGS	31
5.7	SOFT STOP FUNCTION	32
5.8	SUPPLY FREQUENCY SELECTION	33
5.9.1	THYRISTOR TRIGGERING PATTERN.....	33
5.9.2	DAMPING.....	33
5.19	KICK START ENABLING AND PEDESTAL SETTINGS	34
5.11	KICK START TIME.....	34
5.12	CURRENT LIMITING	34
5.13	SYSTEM READY RELAY	35
5.14	RUN/FAULT RELAY	35
5.15	TOP OF RAMP RELAY.....	36
5.16	OVER TEMPERATURE TRIP (55kW to 800kW).....	36
5.17	PCB OPERATIONAL VOLTAGE SELECTION.....	36
5.18	STALLED ROTOR PROTECTION	38
5.19	INTEGRAL COOLING FAN CONNECTIONS	38
5.20	START AND STOP FUNCTION.....	39
5.21	EMERGENCY RUN FUNCTION	39
5.22	PHASE LOSS DETECTION.....	41
5.23	LED INDICATOR FUNCTIONS	42
	APPENDICES	
1	MECHANICAL DRAWINGS	43
2	TESTING AND REPLACEMENT OF THYRISTORS	48
3	GENERAL SPECIFICATIONS	50
4	FAN SPECIFICATION	51
5	HP - kW CONVERSION TABLE	51
6	LPMEC/SS & HPMEC/SS PCB PHOTOGRAPHS	52
7	PCB REPLACEMENT	54
8	CURRENT DERATING CHARTS	57
9	DIP SWITCH SETTINGS	59

1 INTRODUCTION

Thank you for choosing the EnviroStart Motor Energy Control. The system has been designed with ease of use and set up in mind. The majority of applications will operate effectively without the need to make any changes to the default settings however should such changes be necessary please do read through this Installation and Commissioning Guide so as to better understand the effects of the changes you are making, be aware of the fact that changing things like start up pedestal voltage can impact the time it takes for a motor to get to full speed as such controllable features are inter-related.

EnviroStart has been designed to provide a long life; components have been selected with reliability in mind and have generally been over-rated for the power of the unit manufactured. Using the standard IQA, (Institute of Quality Assurance), methodologies the expected lifetime of EnviroStart is rated at 130,000 hours continuous use.

In the unlikely event that you do need further support please contact your local EMS (European) Distributor or failing that contact us directly either by e-mail or fax. All details of how to contact us are available on our web site at <http://www.EnviroStart.com>, please remember that we are constantly updating documentation and information about EnviroStart, all such information is posted and publicly available on the web site.

1.1 FEATURES

The **EnviroStart** is a high specification digital Soft-Start, Motor Energy Control available in models suitable for motors up to 1,400A (Units up to 2,200A available to special order)

In addition to a full featured soft-start, the **EnviroStart** MEC incorporates state of the art Motor Energy Control technology to substantially reduce the electricity consumption of synchronous electric induction motors whilst they are operating at less than their full load capacity.

- ▶ CONFIGURABLE ENERGY CONTROL
- ▶ CONFIGURABLE SOFT START (Ramp times from 0.5s – 60s)
- ▶ CONFIGURABLE INITIAL PEDESTAL VOLTAGE SETTING (25 – 70% of full voltage)
- ▶ CONFIGURABLE SOFT STOP (Ramp times from 5s – 45s)
- ▶ START CURRENT LIMITING (1.5x – 8x FLC of motor)
- ▶ CONFIGURABLE KICK-START (Fully definable, Initial pedestal and time from 0.25s – 2s)
- ▶ SWITCHABLE DIRECT ON LINE START (DOL Start retains all run features)
- ▶ SWITCHABLE EMERGENCY RUN (DOL Start no retention of run features)
- ▶ START/STOP AND EMERGENCY RUN COMMAND FUNCTIONS CONTROLLABLE WITH PNP, (SINK), OR NPN, (SOURCE), INPUT OR SIMPLE CLOSED CONTACT SWITCHING.
- ▶ SWITCHABLE CONTINUOUS THYRISTOR FAULT DETECTION
- ▶ STALLED-ROTOR OR SLOWING-ROTOR PROTECTION
- ▶ AUTO LOCK OUT ON HEATSINK OVER TEMP (PCB or external reset, with PCB LED on units of 55kW – 800kW)
- ▶ READY, TOP OF RAMP AND RUN RELAYS. (2x N/O, 2x N/C 2kVA contacts on each)
- ▶ FULL SYSTEM STATUS LED's
- ▶ ON PCB SYSTEM CPU RESET BUTTON
- ▶ SIMPLE TO INSTALL AND COMMISSION
- ▶ RUGGED HOUSING, IP43, NEMA 1. (Can be fitted into cabinet to increase to IP 65)
- ▶ ON-BOARD CONFIGURABLE SUPPLY VOLTAGE AND FREQUENCY SETTINGS
- ▶ 208V, 220V, 400V, 480V, 575V AND 690V 50/60Hz MODELS AVAILABLE

2 RATING INFORMATION

2.1 CORRECT ENVIROSTART SELECTION

The **EnviroStart** must be rated according to the motor rated current (FLC).

However, on certain applications it may be necessary to oversize the unit to cope with the maximum operating parameters associated with particularly heavy-duty operations such as high repetitive on-load starts or elevated ambient operating conditions. (For this see de-rating details shown on relevant specification sheets).

Please note that these environmental factors (temperature, ventilation, altitude, ambient temperature & relative humidity) do affect sizing and failing to take proper notice of such conditions will invalidate any warranty associated with the system as supplied. Where the **EnviroStart** is expected to operate outside the normal specifications and you are uncertain as to the selection of a unit please contact EMS (European) or your local Distributor, we will always be happy to assist to ensure your application is correctly supported.

IMPORTANT NOTE

THE ENVIROSTART MOTOR ENERGY CONTROL IS A SOPHISTICATED SOLID STATE MOTOR SOFT START AND ENERGY MANAGEMENT SYSTEM WITH A RANGE OF INBUILT PROTECTION DEVICES AND MONITORING SYSTEMS IT IS HOWEVER NOT A REPLACEMENT FOR PROPERLY RATED CURRENT OVERLOADS AND FUSES WHICH SHOULD BE FITTED FOR MAXIMUM PROTECTION OF THE MOTOR.

2.2 VOLTAGE RATINGS AVAILABLE: 208V/480V, 220V/400V, 570V & 690V

The general ratings in this installation and commissioning guide are based on typical four-pole motor characteristics. The **EnviroStart** will however work effectively on two; six and eight pole motors provided they are synchronous in operation.

Ratings are based on the full motor rated current, (FLC). The cable and fuses have to be sized in accordance with the rated output of the unit applicable to the voltage selected on the PCB. Recommendations with regard to fuse and cable ratings are made within this guide, (section 4.13), however it is the responsibility of the installation engineer to ensure that all such fittings are properly rated and specified in accordance with local requirements and conditions.

2.3 CE DECLARATION OF CONFORMITY



MANUFACTURERS DECLARATION OF CONFORMITY

This declaration covers all **EnviroStart** Motor Energy Control units.

This product fulfils the following European Community Directives when applied as follows:

Low Voltage Directive

The above products fulfil the Low Voltage Directive 73/23/EEC, 89/336/EEC and 93/68/EEC amendment for industrial equipment; however, they must be installed to general good electrical engineering practices and regulations by a suitably qualified person with strict reference to the instructions in the product's Technical Manual.

EMC Directive

The above products are intended to be a component in a system or a machine. They must be mounted into an appropriate enclosure and system designed to fulfil the CE directives plus IEC and local industrial standards. Units must be installed by a suitably qualified person to comply with general good electrical engineering practices and regulations with strict reference to the instructions in the product's Technical Manual. To meet all EMC directives, the above products are available with an optional RFI Filter.

IEC-1000-4-2 Level 3; IEC-1000-4-3 Level 3; IEC-1000-4-4 Level 4; IEC-1000-4-5 Level 3; IEC-1000-4-12 Level 3.

The above is based on test results from an independent test laboratory (Steatite Group Ltd.) to test specification EN 50081-2, EN 50082-1 and EN 50082-2.

Harmonised Standards Applicable

BS EN 6094.4.4 (which calls on EN 56011); EN 55022; EN 51000.4.2; EN 61000.4.3; EN 51000.4.4; EN 61000.4.5; EN 61000.4.6; EN 61000.4.8; EN 61000.4.11; BS EN 50081.1; BS EN 50081.2; BS EN 50082.2; EN 6094.4.2; IEC-947-4-1; IEC-68-2-6, (NFC2076; BV1); IEC-947-4-2.

Electrical Requirements Specification G5/4 - 2 (2008)

Dated: July 2009

3 GENERAL SPECIFICATION

3.1 TECHNICAL SPECIFICATION (2.2kW – 3.5kW)

SUPPLY VOLTAGE	220V or 400V (Factory Fitted Option)
FREQUENCY	50Hz or 60Hz selected on PCB.
START DUTY	4 x Rated FLC for 2s, 3 x Rated FLC for 5s, 2 x Rated FLC for 20s
STARTS PER HOUR	20 evenly spaced starts per hour.
ENERGY CONTROL LIMITING	90%, 85%, 75%, 60% (Unit auto levels from this set level to maximum power dependant upon motor torque demand)
PEDESTAL VOLTAGE RANGE	25 – 70% of supply voltage, 6% - 80% available torque.
RAMP UP TIME RANGE	0.5 - 60s
RAMP DOWN	Independently selectable 0.75 x Ramp-Up Time. (From full power)
CURRENT LIMIT TIME	Current limit control on ramp up to 30s from start enable
CURRENT LIMIT RANGE	1.5 – 8.0 x unit rated FLC (infinite adjustment with on PCB pot)
STALLED ROTOR DETECT	Unit shutdown in event of rotor stall
PHASE LOSS DETECT	LED indication and shut-down in case of phase loss
COOLING	Naturally cooled isolated cold-wall cooling
POWER SWITCHING	TO220 or TO247 Isolated Base Triacs
CONTROL CIRCUITRY	24MHz clocked Atmel Surface Mount CMOS MPU
CONTROL SUPPLY	Derived from three phase input
FAULT DETECTION	Shut down if:- Supply or Feed Phase Loss, Motor O/C or S/C Winding, Stalled Rotor, Triac Fault or PCB Logic Fault
LED INDICATIONS	Power On, Motor Run, Motor Top of Ramp, Set Current-Limit Exceeded, Ramp in Progress/Energy Save/End of Ramp Down/Emergency Run/Thyristor Fault Detected
ON PCB RELAYS	Motor Run
RELAY CONTACT RATING	2kVA, 250V AC with 1 N/O
MECHANICAL PROTECTION	IP43, NEMA 1 sheet metal enclosure
OPERATING TEMP.	0°C - +40°C @ < 95% RH. (De-rate 20%/10°C above +40°C)
STORAGE TEMP.	-10°C - +60°C
ALTITUDE	2000m above sea level – De-rate Amps by 1%/100m above 2000m
EU DIRECTIVES	Meets all necessary EMC and Low Voltage Directives

TECHNICAL SPECIFICATION (5.5kW – 800kW)

SUPPLY VOLTAGE	220V or 400V and 208V or 480V selected by PCB links (570V & 690V Units Available)
FREQUENCY	50Hz or 60Hz selected on PCB.
START DUTY	4 x Rated FLC for 5s, 3 x for 20s, 2 x for 30s (5.5 to 37kW units) 5 x Rated Current for 5s, 3 x for 30s, 2 x for 60s (55 to 800kW units)
STARTS PER HOUR	Minimum of 12 evenly spaced starts per hour.
ENERGY CONTROL LIMITING	90%, 85%, 75%, 60% (Unit auto levels from this set level to maximum power dependant upon motor torque demand)
PEDESTAL VOLTAGE RANGE	25 -100% of supply voltage, 6% -100% available torque. (100% is with DOL start selected)
RAMP UP TIME RANGE	0.5 - 60s
RAMP DOWN	Selectable, set at 0.75 x Ramp-Up Time. (From full power)
KICK START	Switch selected
KICK START LEVEL	Selectable at 70% or 90% of maximum supply voltage
KICK START TIME	0.25, 0.5, 1 or 2s
CURRENT LIMIT TIME	Current limit control on ramp up to 30s from start enable
CURRENT LIMIT RANGE	1.5 – 8.0 x unit rated FLC, dependant on motor slip characteristic. (Infinite adjustment with On-PCB pot)
STALLED ROTOR DETECT	Unit shutdown in event of rotor stall
PHASE LOSS DETECT	Selectable, LED indication and shut-down in case of phase loss
COOLING	Naturally cooled, isolated heatsink up to 45A (22kW). Fan assisted cooling 60A, (30kW), and above (Independent 240/110V supply required)
THERMAL CUT OUT	Automatically cuts out and latches out in event of >90°C on heatsink. (55kW to 800kW). PCB or External reset required to re-start
POWER SWITCHING	Fully base-isolated twin thyristor Paks or independent Pucks
CONTROL CIRCUITRY	48MHz clocked Atmel CMOS MPU
CONTROL SUPPLY	Derived from three phase input
FAULT DETECTION	Shut down if:- Supply or Feed Phase Loss, Motor O/C or S/C Winding, Stalled Rotor, Thyristor Fault or PCB Logic Fault
LED INDICATIONS	Power On, Motor Run, Motor Top of Ramp, Set Current-Limit Exceeded, Ramp in Progress/Energy Save/End of Ramp Down/Emergency Run/Thyristor Fault Detected/Phase Loss Detected
ON PCB RELAYS	System Ready, Motor Run/Fault and Motor Top of Ramp
RELAY CONTACT RATING	2kVA, 250V AC with 2 N/O and 2 N/C contacts
MECHANICAL PROTECTION	IP43, NEMA 1 sheet metal enclosure or high impact ABS cover on heat sink backplane (depending on kW rating)
OPERATING TEMP.	0°C - +40°C @ < 95% RH. (De-rate 20%/10°C above +40°C)
STORAGE TEMP.	-10°C - +60°C
ALTITUDE	2000m above sea level – De-rate Amps by 1%/100m above 2000m
EU DIRECTIVES	Meets all necessary EMC and Low Voltage Directives
UL COMPLIANCE	Compliant for US and Canadian - File E192379 (55kW to 800kW units)

3.2 HIGH SPEED FUSES – (55kW to 800kW)

The **EnviroStart** has provision for integral High Speed Semiconductor Fuses to be fitted. These are not fitted as standard. Customers requiring integral fuses for the output feed to the motor must specify this at the time of order. In general, if BS 88, motor rated fuses are fitted to the incoming supply of the unit as is recommended within IEE 17th Edition Regulations, (this being the applicable regulations document in the UK), then these additional fuses are not necessary.

There is no provision for integral fuses to be fitted to the output of the 2.2kW to 37kW **EnviroStart** units.

3.3 HARMONICS

EnviroStart like all electronic systems does produce low level harmonics during Ramp Up, Ramp Down and Energy Control and when not at full or zero volts.

U.K. electricity council engineering recommendations contained within their documents G5/4 (2002), specifies that the short term generation of harmonics by any electronic system on a typical 100kVA supply should not exceed 56A of 5th harmonic and 40A of 7th harmonic. Assuming a 415V supply this equates to one motor of around 145A, therefore the maximum 5th harmonic is 37% and the 7th 28%. The specification also details that the concern is primarily with the possibility of damage to frequency dependent components (such as capacitors) through long-term exposure to such harmonics.

As the **EnviroStart** units produce negligible harmonic levels during normal running it is excluded from the constraints of such specifications by definition; however with our policy of ensuring maximum compliance and minimum environmental pollution our design standards ensure that we fall well below the limits set. Typical test values* of harmonic currents on an **EnviroStart** controlled motor operating in Energy Save Mode yielded <8% for 5th Harmonic and <1% for 7th harmonic, significantly within the accepted and specified limits.

Maximum limits are unlikely to be exceeded in normal operation even during ramp up and ramp down periods

**Based on tests carried out on a 22kW motor by University Of Surrey Industrial Electronics Group November 1988, re-verified on current Generation V product in July 2003.*

3.4 HEAT LOSES

For heat calculation purposes it should be assumed that **EnviroStart** units have a power loss of 1.2W/A per phase at full conduction, (3.6W/A maximum for the three phase). These losses cause heat to be generated that is safely dissipated through the aluminium heatsink or thermal cold-wall, (2.2kW and 3.5kW). See Section 4.9.

3.5 HEAT DISSIPATION

In order to keep the unit operating within its design limits any proposed additional enclosure must be capable of safely dissipating the energy generated by the **EnviroStart**.

When fitting systems up to 205A FLC into enclosures, (to extend protection from the standard IP43 up to IP 65/NEMA 2), the fitting louvers of the minimum specification (described in Section 3.9 - Table of Power Losses) both above and below the **EnviroStart** as sited within the cabinet will normally be sufficient to ensure effective heat dissipation.

With units of >205A, additional fans must be fitted to the cabinet in addition to those fitted to the **EnviroStart**. The following information will help the user to select a fan to keep the temperature rise within the control panel to a 10°C rise above external ambient.

3.6 SELECTING A CABINET COOLING FAN

Take the heat dissipation figure of the required **EnviroStart** model from Section 3.10, Table of Power Losses. Compare this figure with the fan heat disposal figure in Section 3.9, Table of Fan Data and select a fan with a greater heat disposal figure than that calculated.

For example, **EnviroStart** 90kW Model gives a heat dissipation figure of 632W, requiring a 7600N model fan with filter equivalent to cooling of 805W.

3.7 CONTROL PANELS WITH MULTIPLE ENVIROSTARTS

If more than one **EnviroStart** is to be installed in a single enclosure the heat dissipation figures should be added together before selecting cooling system requirements.

3.8 COOLING FAN POSITION

The fans should be positioned below the **EnviroStart** power assembly to allow cool air to be drawn into the path of the power assembly fans. Outlet Filters or louvers should be positioned close to the top of the enclosure and in the path of the airflow. These should be approximately double the fan apertures to ensure that the air flow is as free as possible.

3.9 CABINET COOLING FAN DETAIL

The fans should be positioned in the cabinet, wherever possible, below the **EnviroStart**. The aperture to which the fans are fitted should always be large enough to allow free flow of air, any filters fitted should be selected to minimise their interruption to air flow. Such filters should be regularly inspected to ensure that they are clean.

PAPST FAN MODEL NO.'S	FLOW RATE EXC. FILTER (L/s.)	FLOW RATE INC. FILTER (L/s.)	HEAT DISP. EXC. FILTER (W)	HEAT DISP. INC. FILTER (W)
8500N/8550N	10.4	8.3	117	93
4600N/4650N	38.7	31	477	382
7600N/7650N	87.3	71	1,010	805
7400N/7450N	106	85	1,166	935
6028S/6078	106	93.3	1,283	1,026

3.10 POWER LOSSES

MODEL	POWER ASSEMBLY LOSSES IN W.	CONTROL & FAN LOSSES IN W	TOTAL LOSSES IN W	MINIMUM LOUVRE AREA (TWO REQUIRED)
TPMECG6 - 2.2	30	12	42	None
TPMECG6 - 3.5	35	12	37	None
TPMECG6 - 5.5	45	10	55	0.0156 Sq. M
TPMECG6 - 7	58	10	68	0.0156 Sq. M
TPMECG6 - 11	90	10	100	0.0156 Sq. M
TPMECG6 - 15	108	10	118	0.0156 Sq. M
TPMECG6 - 22	162	10	172	0.0156 Sq. M
TPMECG6 - 30	216	50	266	0.0625 Sq. M
TPMECG6 - 37	270	50	320	0.0625 Sq. M
TPMECG6 - 55	306	50	356	0.0625 Sq. M
TPMECG6 - 63	432	50	482	0.0625 Sq. M
TPMECG6 - 75	522	50	572	0.0625 Sq. M
TPMECG6 - 90	612	50	662	0.1 Sq. M
TPMECG6 - 110	738	50	788	0.1 Sq. M
TPMECG6 - 132	918	70	988	See Sections 3.6 - 3.8
TPMECG6 - 150	1,044	70	1,114	See Sections 3.6 - 3.8
TPMECG6 - 186	1,224	85	1,309	See Sections 3.6 - 3.8
TPMECG6 - 225	1,476	85	1,561	See Sections 3.6 - 3.8
TPMECG6 - 260	1,710	85	1,795	See Sections 3.6 - 3.8
TPMECG6 - 315	2,088	135	2,223	See Sections 3.6 - 3.8
TPMECG6 - 375	2,412	135	2,547	See Sections 3.6 - 3.8
TPMECG6 - 450	2,880	160	3,040	See Sections 3.6 - 3.8
TPMECG6 - 500	3,440	160	3,600	See Sections 3.6 - 3.8
TPMECG6 - 630	3,960	260	4,220	See Sections 3.6 - 3.8
TPMECG6 - 800	4,500	300	5,100	See Sections 3.6 - 3.8

USE TABLE OF FAN DATA IN SECTION 3.9 TO SELECT CORRECT CABINET FAN

IT IS VITALLY IMPORTANT THAT YOU REVIEW THE DERATING INFORMATION IN APPENDIX 8 OF THIS INSTALLATION GUIDE TO ENSURE THAT YOU CHOOSE A SYSTEM RATED TO MEET YOUR APPLICATION DEMANDS

4 INSTALLATION

4.1 IMMUNITY FROM INTERFERENCE

EnviroStart generally has a high level of immunity to externally generated interference. However the following good practices should be observed:

4.2 COIL SUPPRESSION

Any coil that is connected to the **EnviroStart**, shares a common control supply or is mounted in the same enclosure must be suppressed using appropriate R-C filter circuits.

4.3 LIGHTNING STRIKES/VERY HIGH VOLTAGE TRANSIENTS

In areas subject to frequent lightning strikes or other high voltage transients, a suitably rated metal oxide Varistor (MOV) or transient voltage suppressor (TVS) should connect each input line to earth.

4.4 CONTROL VOLTAGE TRANSIENTS

Where the control supply to the **EnviroStart** is thought to be subject to mains-borne interference a suitable line filter with transient interference suppression should be fitted between the control supply and the **EnviroStart**.

4.5 INPUT/OUTPUT CONTROL CONNECTIONS

To avoid 'interference pick up' all input and output control cables should be kept as short as possible and should wherever possible, be shielded. If noise free lines cannot be guaranteed, an interposing relay with suitable suppression must be used, this should be mounted as close to the **EnviroStart** as possible.

4.6 EMISSIONS

EnviroStart units produce relatively low Radio Frequency Interference (RFI) compared with frequency inverters and no external filters are required in normal circumstances.

4.7 BY-PASS CONTACTOR (Not Recommended)

In the unlikely event that the **EnviroStart** is only used for "soft-starting", a by-pass contactor can be used to short the unit at top of ramp to eliminate the need for cooling.

The by-pass contactor should be Motor DOL rated. Normally it will not be switching current but it will be expected to be able to do so under fault conditions.

4.8 VENTILATION

The **EnviroStart** must be mounted vertically with the cooling fans, (if fitted), directing the air upwards. A free space of 85mm must be allowed above and below the unit. See section 3.4 through 3.10 for further information.

4.9 COS. PHI CORRECTION (Power Factor Correction)

Power factor correction capacitors **must never** be connected to the output of the **EnviroStart** motor energy control. They must be fitted to the supply side of the line contactor, (or isolator), and switched by the line contactor, (or isolator), so they are never in direct line with the **EnviroStart**.

4.10 BURDEN RESISTOR SETTINGS (CURRENT SENSE CIRCUIT)

In order for the system software to be able to properly manage the ramp up and over current protection it is necessary that the burden resistor value be set correctly for the size of motor it is operating. The burden resistor works in parallel with the over current limit potentiometer VR1 during ramp up and is therefore important for the effective operation of the system if current limiting is required during this ramp up period.

Burden resistor values are selected on the Burden Resistor DIP Switch located on the PCB according to the following table. There are no individual Burden Resistors to set on the 2.2kW to 3.5kW **EnviroStart** units as the current sense burden resistor value is fixed on these two items.

UNIT SIZE	SW 1	SW 2	SW 3	SW 4	SW 5	SW 6	SW 7	SW 8
400-TPMECG6 - 5.5	OFF	OFF	OFF	OFF				
400-TPMECG6 - 7	OFF	OFF	OFF	ON				
400-TPMECG6 - 11	OFF	OFF	ON	OFF				
400-TPMECG6 - 15	OFF	OFF	ON	ON				
400-TPMECG6 - 22	OFF	ON	OFF	ON				
400-TPMECG6 - 30	ON	ON	OFF	OFF				
400-TPMECG6 - 37	ON	ON	ON	OFF				
400-TPMECG6 - 55	OFF	ON	OFF	ON	OFF	OFF	OFF	ON
400-TPMECG6 - 63	OFF	OFF	OFF	ON	OFF	OFF	ON	OFF
400-TPMECG6 - 75	OFF	OFF	OFF	OFF	ON	ON	ON	OFF
400-TPMECG6 - 90	OFF	ON	OFF	ON	OFF	OFF	OFF	ON
400-TPMECG6 -110	OFF	OFF	ON	ON	ON	ON	OFF	ON
400-TPMECG6 - 132	OFF	OFF	OFF	OFF	OFF	OFF	OFF	OFF
400-TPMECG6 - 150	OFF	ON	OFF	OFF	OFF	OFF	OFF	OFF
400-TPMECG6 - 186	OFF	ON	OFF	ON	OFF	OFF	OFF	OFF
400-TPMECG6 - 225	OFF	OFF	OFF	ON	OFF	ON	OFF	OFF
400-TPMECG6 - 260	OFF	OFF	ON	OFF	ON	ON	OFF	OFF
400-TPMECG6 – 315	OFF	ON	OFF	OFF	ON	OFF	OFF	ON
400-TPMECG6 - 375	OFF	ON	ON	ON	OFF	OFF	ON	OFF
400-TPMECG6 - 450	OFF	OFF	OFF	ON	OFF	OFF	OFF	ON
400-TPMECG6 – 500	OFF	ON	ON	ON	OFF	OFF	OFF	ON
400-TPMECG6 - 630	OFF	ON	OFF	OFF	OFF	OFF	ON	ON
400-TPMECG6 - 800	ON	ON	ON	ON	ON	ON	ON	ON

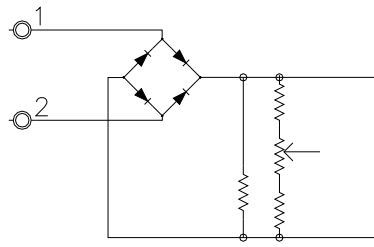

Current Sensing Cct.

2.2kW through 3.5kW CT Connection

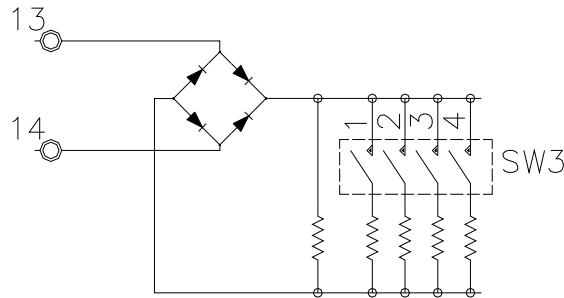

5.5kW through 37kW Burden Resistor Configuration and CT Connection

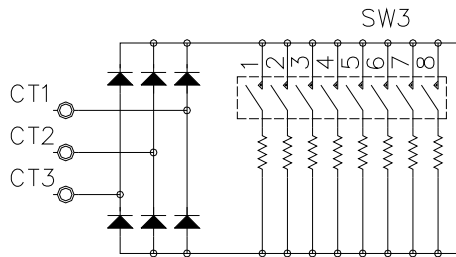

55kW through 800kW Burden Resistor Configuration and CT Connection

4.11 SLIP-RING MOTORS

EnviroStart units are suitable for Slip Ring Motors provided that a single stage resistance is added, (during start up), to the rotor circuit, this having a resistance of approximately 10-20% rotor Ohms, ($R\Omega$). (This is typically going to be $0.3 - 0.5\Omega$). This resistance induces additional magnetic flux in the rotor and gives the motor a similar torque characteristic to that of a multi-stage resistance bank started slip ring motor. Care must be taken when fitting **EnviroStart** units to slip ring motors. If you are in any doubt please contact your local Distributor or Agent or contact EMS (European) directly.

Some slip ring motors not only have passive induced current in the rotor at start up but have a direct DC injection through the start up phase. Such motors can also be started with **EnviroStart** units however care must be taken to ensure that the **EnviroStart** is correctly sized to fit the motor FLC and that the **EnviroStart** is not connected to the DC input. If you are in any doubt please contact your local Distributor or Agent or contact EMS (European) directly.

4.12 LOAD SIZE

The **EnviroStart** unit must be connected to a motor for the system to operate. The motor and the **EnviroStart** should be matched for both kW and FLC rating. Motors regularly operating at below 5% of their kW rating are not suitable for use with **EnviroStart** control as this low level operation may cause instability of thyristor firing resulting in the motor stalling.

It is important to make an assessment of the load type and frequency of starts as well as the operating ambient conditions when selecting a suitable **EnviroStart** unit. High frequency of starts, elevated ambient temperatures or significant altitude should be treated carefully and consideration given to selecting the next size of **EnviroStart** up from that which would be selected simply on kW or FLC ratings alone.

4.13 CABLE AND INPUT FUSE RATINGS

Incoming fuses and power cables must comply with the ratings as shown in the table below. It is recommended that all cable be tri-rated compliant with BS 6231 and that all fuses be motor rated, bolt fitting, compliant with BS 88 Part 2.

MODEL	FUSE RATING	CABLE RATING		MODEL	FUSE RATING	CABLE RATING
400-TPMECG6 – 2.2	8A	14A/0.75mm/20AWG		400-TPMECG6 -110	200M250A	204A/50mm/2/0AWG
400-TPMECG6 – 3.5	10A	14A/0.75mm/18AWG		400-TPMECG6 - 132	250M300A	259A/70mm/4/0AWG
400-TPMECG6 – 5.5	16A	14A/0.75mm/16AWG		400-TPMECG6 - 150	315M400A	321A/95mm/300MCM
400-TPMECG6 - 7	20M32A	21A/1.5mm/14AWG		400-TPMECG6 - 186	355A	374A/120mm/350MCM
400-TPMECG6 - 11	25A	30A/2.5mm/12AWG		400-TPMECG6 - 225	400A	440A/150mm/400MCM
400-TPMECG6 - 15	32M50A	41A/4mm/10AWG		400-TPMECG6 - 260	500A	500A/185mm/700MCM
400-TPMECG6 - 22	50A	53A/6mm/6AWG		400-TPMECG6 – 315	560A	600A min/800MCM
400-TPMECG6 - 30	63M100A	75A/10mm4AWG		400-TPMECG6 - 375	670A	700A min/1250MCM
400-TPMECG6 - 37	80A	75A/10mm/3AWG		400-TPMECG6 - 450	800A	850A min
400-TPMECG6 - 55	100M160A	100A/16mm3AWG		400-TPMECG6 – 500	900A	950A min
400-TPMECG6 - 63	125A	136A/25mm/2AWG		400-TPMECG6 - 630	1100A	1200A min
400-TPMECG6 - 75	160A	167A/35mm/1/0AWG		400-TPMECG6 - 800	1400A	1500A min
400-TPMECG6 - 90	200M250A	204A/50mm/2/0AWG				

Connections on 5.5kW through 37kW are direct onto the thyristor packs using M5 screws. From 55kW through to 800kW M8 thread bolt screws are used. A single termination point recommended on 55kW through to 110kW, a double termination point recommended for 132kW through 375kW and four termination points recommended on units above 375kW.

The above detail refers to new installations. In cases where the **EnviroStart** is being fitted into an existing installation then the cable should be rated according to the fuses already fitted. (IEE 17th Regulations). The AWG and MLM designations are per Table 310-16 of NEC 2005 and relate to copper conductors. (60°F up to 100A and 75°F above 101A).

4.14 BUS BAR CONNECTION

Where used, bus bars are either pure aluminium or, on systems rated at 255A and above, are nickel plated copper. All bus bars are dual rated, in that either aluminium or copper connectors can be used with them however on the aluminium bus bars it is recommended that a small amount of thermal grease be used if copper connectors are being used.

CONNECTION

4.15 TERMINAL FUNCTION AND LOCATION (2.2kW and 3.5kW))

IT IS IMPERATIVE THAT ALL ENVIROSTART UNITS SHOULD BE MOUNTED VERTICALLY TO ALLOW AIR FLOW THROUGH THE HEATSINK. IF IN ANY DOUBT ABOUT MOUNTING PLEASE CONTACT YOUR LOCAL DISTRIBUTOR OR EMS (EUROPEAN) LTD.

TERMINAL	LOCATION	FUNCTION
L1/L2/L3	Power Assembly	Red/Yellow/Blue Phase Supply (Dual Connectors Available)
U/V/W	Power Assembly	Red/Yellow/Blue Phase Output to Motor
EARTH	Power Assembly	Earth Connection to Unit
1 & 2	PCB	Current Sense Input from CT
3 & 4	PCB	TOR Relay N/O
5 & 6 ²	PCB	Emergency Run Enable
7 & 8 ¹	PCB	Start and Stop Enable

NOTES

1. Terminals 7 and 8 should be permanently linked (via switch or link) to cause the motor to start. When the connection between the terminals is open circuit but the unit is still powered up the motor will stop.
2. Terminals 5 and 6 should be permanently linked (via switch or link) to enable the emergency run function. When the connection between the terminals is open circuit but the unit is still powered up the motor will stop. It is not necessary to have a link across connectors 7 and 8 if the emergency run function is enabled.

TERMINAL FUNCTION AND LOCATION (5.5kW to 800kW)

TERMINAL	LOCATION	FUNCTION
L1/L2/L3	Power Assembly	Red/Yellow/Blue Phase Supply
U/V/W	Power Assembly	Red/Yellow/Blue Phase Output to Motor
240V or 110V	Power Assembly	Cooling Fan Supply Voltage (55kW and above) Integrated supply on units manufactured after February 2006
EARTH	Power Assembly	Earth Connection to Unit
TS1 & TS2	PCB	Thermocouple feed to PCB (55kW and above) See Page 36
K1 (L1) & G1	PCB	Thyristor 1 Cathode and Gate
K2 (U) & G2	PCB	Thyristor 2 Cathode and Gate
K3 (L2) & G3	PCB	Thyristor 3 Cathode and Gate
K4 (V) & G4	PCB	Thyristor 4 Cathode and Gate
K5 (L3) & G5	PCB	Thyristor 5 Cathode and Gate
K6 (W) & G6	PCB	Thyristor 6 Cathode and Gate
1, 2, 3, 4 ¹	PCB	Start (must be kept closed for motor to run)
5,6,7,8 ²	PCB	Emergency Run Energy Save Disable See Section 5.4
9 & 11	PCB	AC Mains Input From Control Transformer (208V, 220V, 400V, 480V, 570V, 690V), Providing 12 – 20V AC
10	PCB	DC Common Rail (At PCB Earth Potential)
12	PCB	DC Input 7V – 24V (External PCB logic circuit supply)
15, 16, 17	PCB	TOR Relay Changeover Contact Pair
18,19, 20	PCB	TOR Relay Changeover Contact Pair
21,22, 23	PCB	Run/Fault Relay Changeover Contact Pair
24, 25, 26	PCB	Run/Fault Relay Changeover Contact Pair
27, 28,29	PCB	Power On/Ready Relay Changeover Contact Pair
30, 31, 32	PCB	Power On/Ready Relay Changeover Contact Pair
33,34,35,36 ³	PCB	Thermal Trip External Reset Connector (55kW and above)
CT1 OR 13	PCB	CT1 +tve Input
CT2	PCB	CT2 +tve Input (55kW and above)
CT3 OR 14	PCB	CT Common Input
220V	PCB	PCB Supply Control Transformer Tapping 220V
400V/570V/690V	PCB	PCB Supply Control Transformer Higher Voltage Tapping
OV	PCB	PCB Supply Control Transformer OV

NOTES

1. Terminals 1, 2, 3, 4 should be permanently linked (via switch or link) per the diagrams below to cause the motor to start. The circuit is designed to accommodate, direct switching, NPN, (sink) or PNP (source) switching should it be necessary to switch directly from a PLC or other micro device. When the connection between the terminals is open circuit but the unit is still powered up the motor will stop.

2. Terminals 5, 6, 7, 8 are dual function, dependant upon DIP Switch 18, these terminals switch either emergency run with a Logic-1, (High – closed circuit), input or disable energy save with a Logic-1, (High – closed circuit), input. With DIP Switch 18 in the OFF position the terminals should be permanently linked (via switch or link) per the diagrams below to enable the emergency run function. (For clarity only the emergency run function is shown on the diagrams however this can be seen as “energy save disable” dependant on the position of the conditional DIP Switch 18). With DIP Switch 18 in the ON position the terminals should be permanently open to allow energy saving. The circuit is designed to accommodate, direct switching, NPN, (sink) or PNP (source) switching should it be necessary to switch directly from a PLC or other micro device.
3. Terminals 33, 34, 35, 36 should be permanently linked (via switch or link) per the diagrams below to reset the thermal overload trip. The circuit is designed to accommodate, direct switching, NPN, (sink) or PNP (source) switching should it be necessary to switch directly from a PLC or other micro device. When the connection between the terminals is made the thermal trip will reset, if the control function on connection 1, 2, 3, 4 is closed at this time then the motor will restart.

4.16 MAINS CONNECTION SCHEMATIC DRAWING (2.2kW to 800kW)

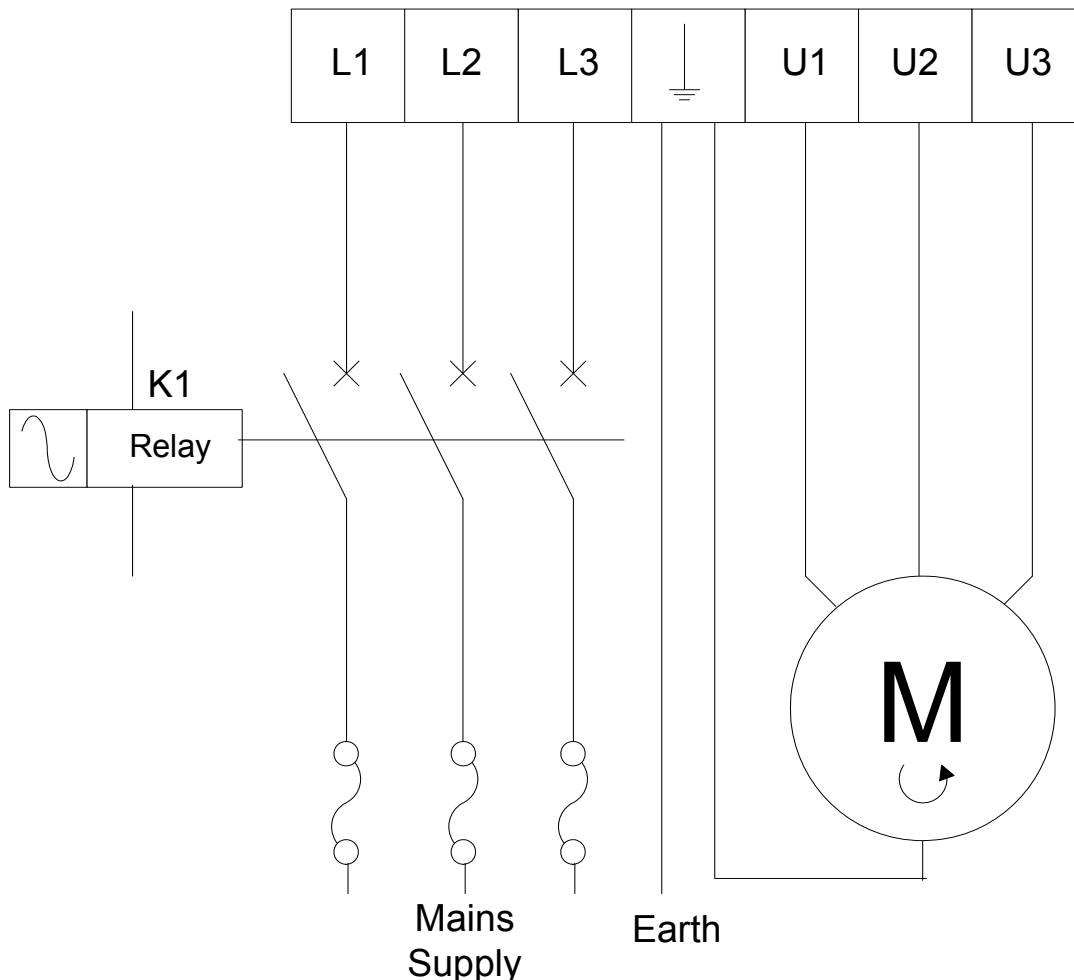

NOTES

1. Should it be required a bypass contactor, (not recommended), could be placed between the Line Input and Motor Feed lines. This contactor would have to be full motor current rated and would be switched using the TOR relay of the **EnviroStart**

CONTROL CONNECTIONS UTILISING ALL FEATURES (5.5kW to 800kW)

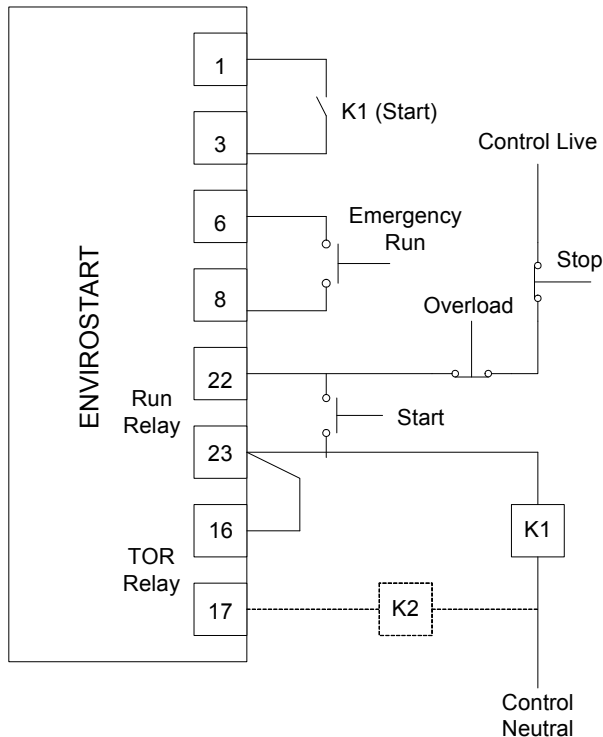

1. The start connection across connectors 1 and 3, (K1 auxiliary) can be permanently linked to start as soon as K1 closes. (Connectors 2 and 4 linked).
2. The run relay acts as a retaining contact for the start push button. In the event of a fault the run relay will open terminals 22 and 23 and therefore de-energise L1, provided that the start push button is not held in.
3. **EnviroStart** can be forced to run even if the control circuit is faulty by closing contactors 5 and 6. This can be done with an associated holding circuit, (not shown) or with a hard wired switch or link.

4.17 CONTROL CONNECTIONS MINIMUM REQUIREMENTS (5.5kW to 800kW)

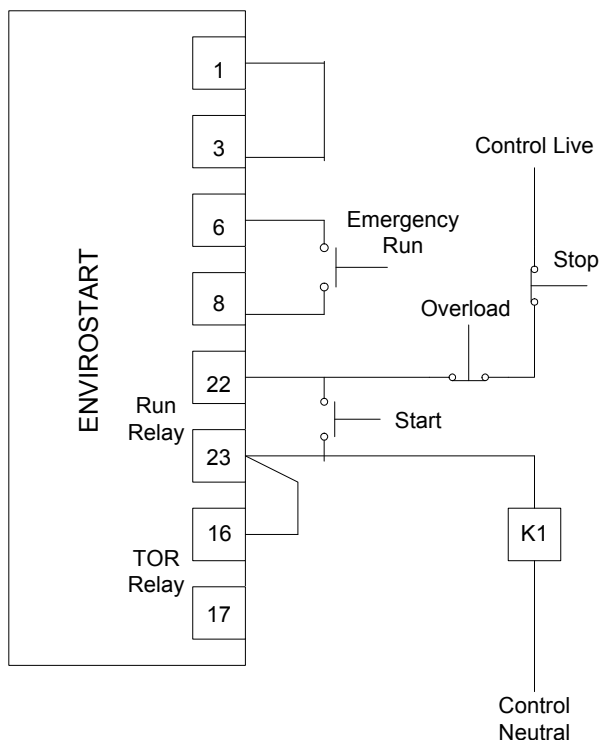

1. The unit will start as soon as K1 closes and places power onto the system circuit. (Permanent link also required between connectors 2 and 4).
2. The run relay acts as a retaining contact for the start push button. In the event of a fault, the run relay will open connectors 22 and 23 and will de-energise K1.
3. **EnviroStart** can be forced to run even if the control circuit is faulty by closing contactors 5 and 6. This can be done with an associated holding circuit, (not shown) or with a hard wired switch or link.

4.18 CONTROL CONNECTIONS – AUTOMATIC START/EMERGENCY RUN (5.5kW to 800kW)

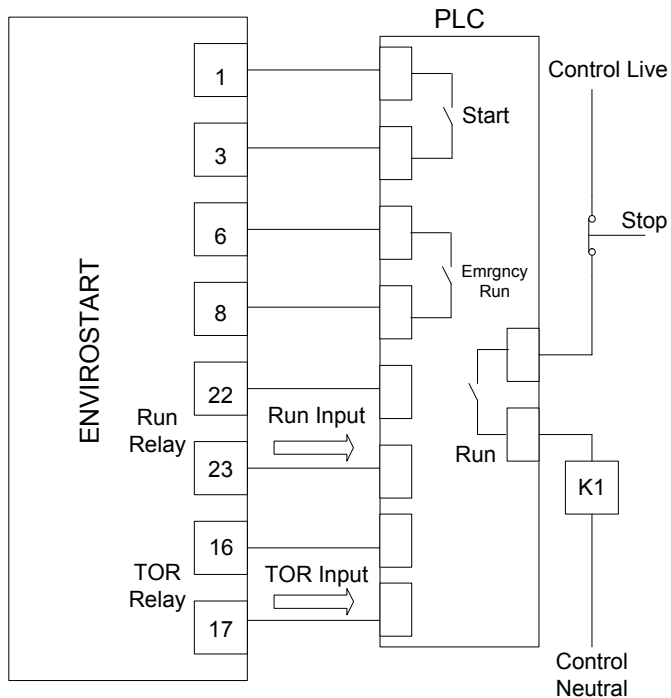

1. The unit will start as soon as K1 closes and then the “Start” is made. The **EnviroStart** will stop when the “Start” function is made open circuit. (Link also to be made between connectors 2 and 4).
2. If the run input is not made shortly after the start signal is given the system will register it as a fault and the PLC will open K1 and lock out until a reset signal is delivered.
3. **EnviroStart** can be forced to run even if the control circuit is faulty by closing contactors 5 and 6. This can be done with an associated holding circuit, (not shown) or with a hard wired switch or link.

4.19 CONTROL CONNECTIONS AUTOMATIC START (5.5kW to 800kW)

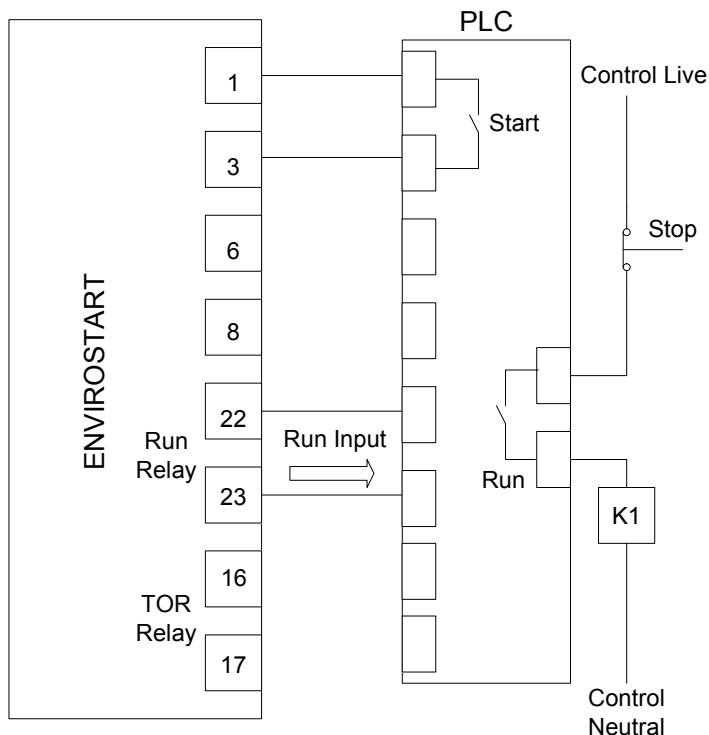

1. The unit will start as soon as K1 closes and then the “Start” is made. The **EnviroStart** will stop when the “Start” function is made open circuit. (Link also to be made between connectors 2 and 4).
2. If the run input is not made shortly after the start signal is given the system will register it as a fault and the PLC will open K1 and lock out until a reset signal is delivered.

4.20 STAR DELTA CONNECTION (5.5kW to 800kW)

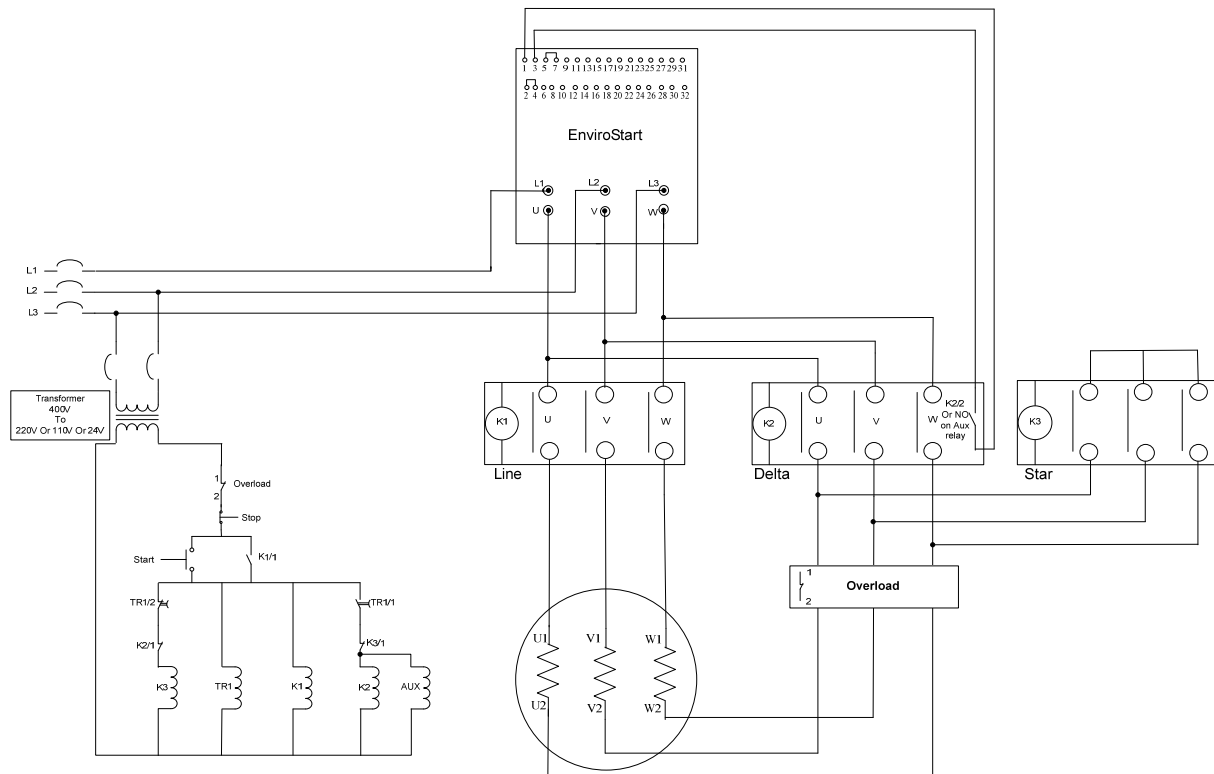

COMMISSIONING

4.21 PRE-COMMISSIONING CHECKS

IMPORTANT: Before installation check the motor rating plate and Section 2 of this manual to ensure that the EnviroStart is correctly rated for the application.

1. Check that the voltage for the PCB and frequency selection is correct.
2. Ensure that fans (if fitted) are connected to the correct voltage and are free to rotate
3. Ensure that all Switch and Potentiometer settings are set to default. (Table 6.1)
4. Check that the unit is connected correctly as per the proceeding connection diagrams.
5. Ensure any PFC Capacitors, if fitted, are placed on the input side of the unit and are only switched in or out when the **EnviroStart** is not running. (See Section 4.9).
6. Ensure that a suitable time has elapsed since the **EnviroStart** was last run/started.

4.22 COMMISSIONING INSTRUCTIONS

1. Check that all settings are at 'Default' and the pre-commissioning steps have been followed.
2. Give the start command to the PCB.
3. Check rotation, if the direction of rotation is incorrect then change over two of the output phase connections marked U, V and W.
4. Default settings should give a satisfactory start with most applications. If it does but you want to further limit current during start up then stop the motor and move to 12 below.

Carry Out the following procedure only if the default start sequence established proves unsatisfactory, this may occur if you have a high inertia load. The following does not have any form of current limit enabled and therefore may not be suitable should you be trying to limit current excursion during start up.

5. Ensure the current limit potentiometer VR1 is fully anti-clockwise at its maximum setting.
6. Set switches 1, 2 and 3 to the minimum ramp time of 0.5s
7. Set switches 8 and 9 to give the maximum pedestal voltage. (Leave switch 10 in the OFF position)
8. Start the motor. The motor should begin to rotate immediately.
9. Check rotation, if the direction of rotation is incorrect then change over two of the output phase connections marked U, V and W.
10. With these settings the unit should start and ramp very rapidly to full speed. If it does not then you should check supply and feed connections are the correct way round and that all connections are made and that all phases are available on the input, L1, L2 and L3 side of the thyristors.
11. If the unit starts satisfactorily then increase the ramp time from 0.5s to a suitable setting, 10s or 20s are typical, and step by step reduce the pedestal voltage setting until a smooth start is achieved

Carry out the following procedure if you want to limit the current at start up.

12. Turn the current limit potentiometer to minimum, fully clockwise; this is the maximum current limit setting.
13. Start the motor; it is likely that the motor will not rotate. This is expected.
14. Slowly turn the potentiometer VR1 anti-clockwise until the motor starts to move, then turn through approximately a further 10° at which point the motor should have sufficient current to accelerate the load to full speed smoothly. This point is the point at which the **EnviroStart** is providing sufficient power to start the load whilst limiting the current by the maximum amount. The Current Limit should not be set too low, as this will cause motor overheating and tripping of the thermal overload in the supply system if they are fitted.
15. With the Current Limit set, the ramp time may need reducing to give the required starting time.
16. Should you want you can monitor the current at start up using a fast acting current clamp meter or Three Phase Analyser set to peak current hold. The clamp should be placed on one of the output feed cables to the motor.

4.23 SETTING FEATURES

When a satisfactory start is achieved the user control functions can be tailored to your specific requirements following the details contained within Section 6 of this Guide. In this be careful not to make changes to the user settings that will impact the effective and proper start of the motor. Care should be taken when making adjustments to the features that start current limits which may have been set during the commissioning sequence above are not exceeded as this may cause damage to preset overloads or fuses external to the **EnviroStart**.

4.24 PCB SWITCH AND CONTROL LOCATION

TPMECG6-2.2 to TPMECG6-3.5 PCB DETAILS

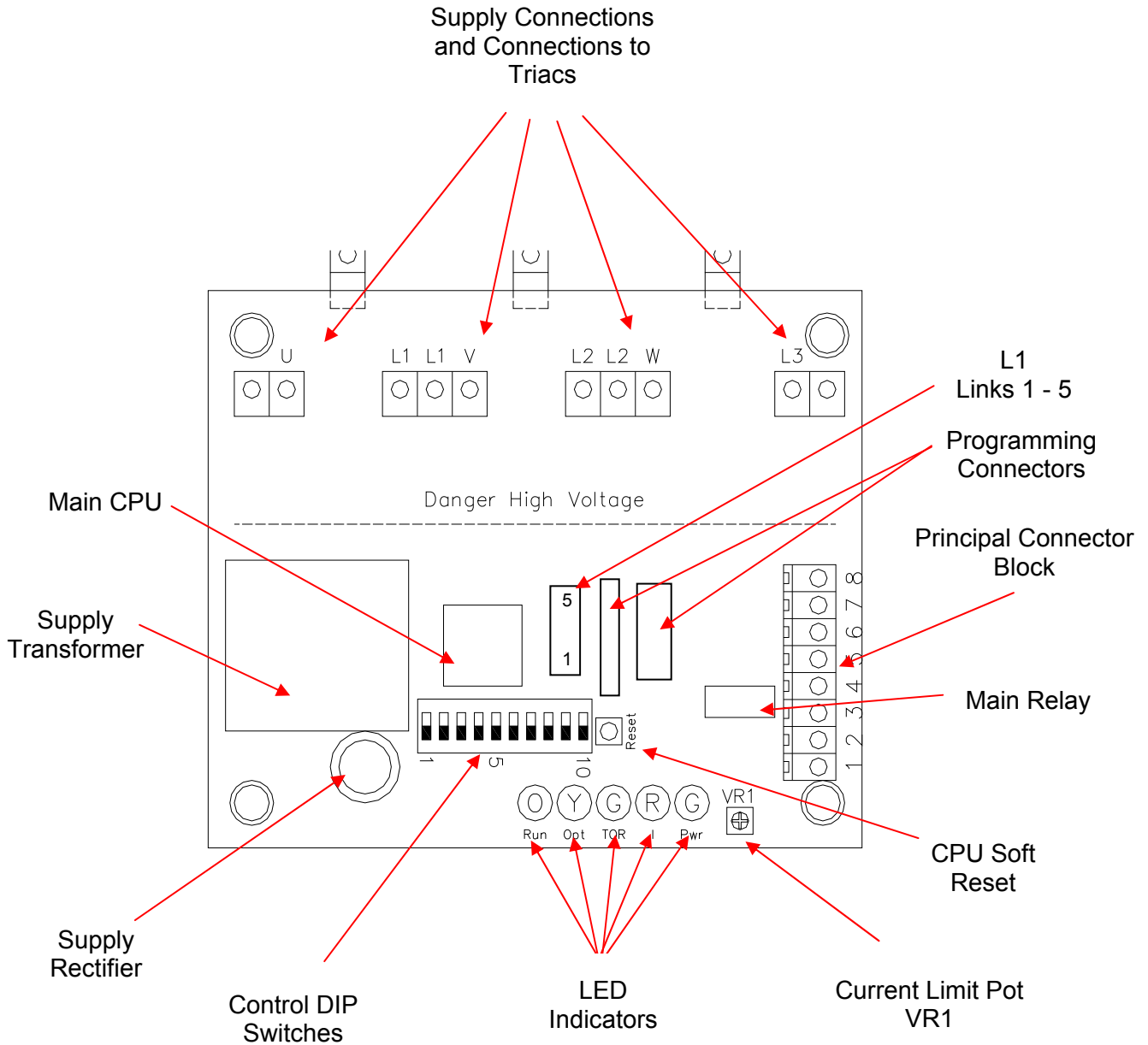

(See Appendix 5 on Page 48 for a photograph of this PCB)

PCB SWITCH AND CONTROL LOCATION

TPMECG6-5.5 to TPMECG6-37 PCB DETAILS

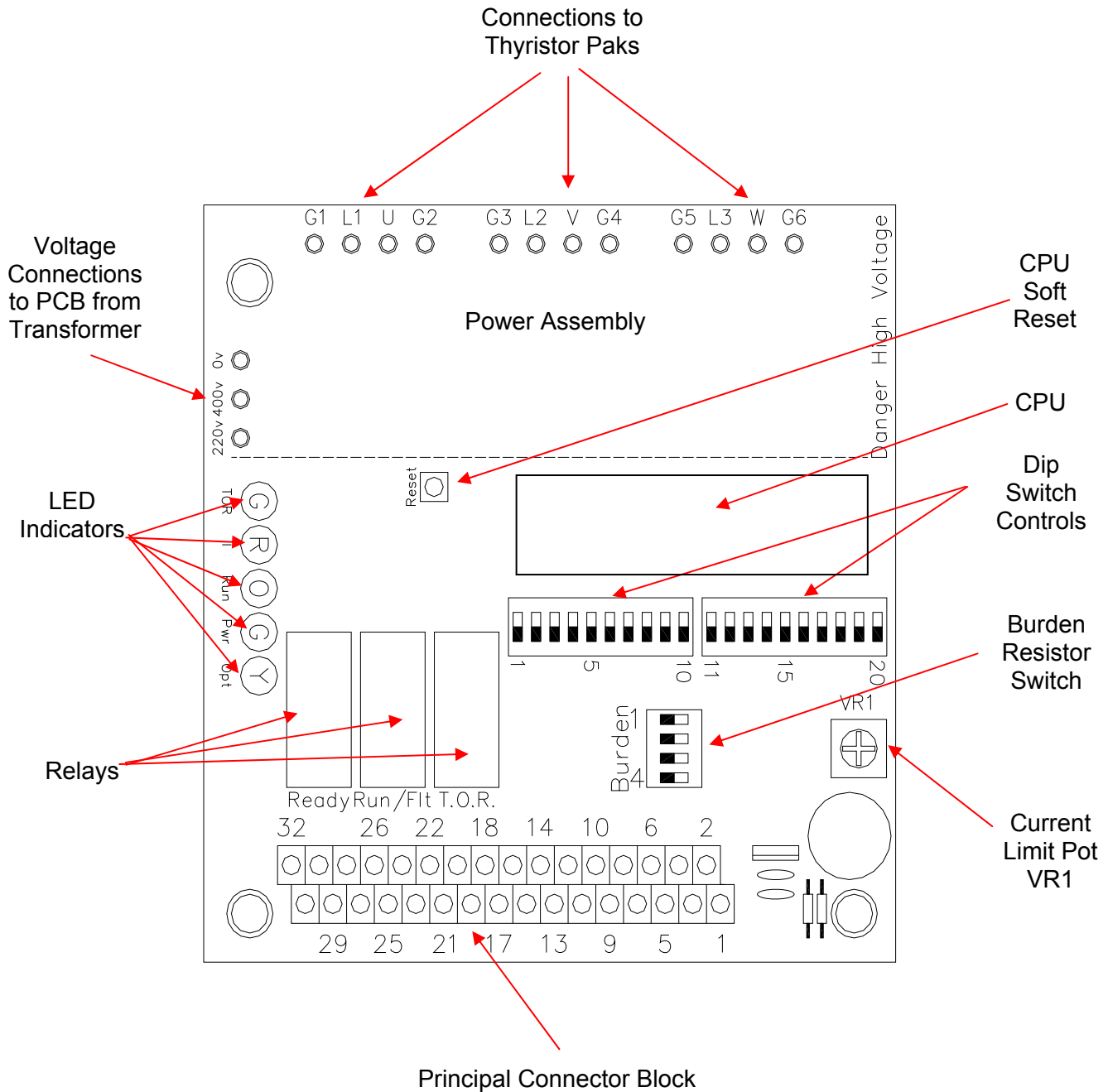

(See Appendix 5 on Page 48 for a photograph of this PCB)

PCB SWITCH AND CONTROL LOCATION

TPMECG6-55 to TPMECG6-800 PCB DETAILS

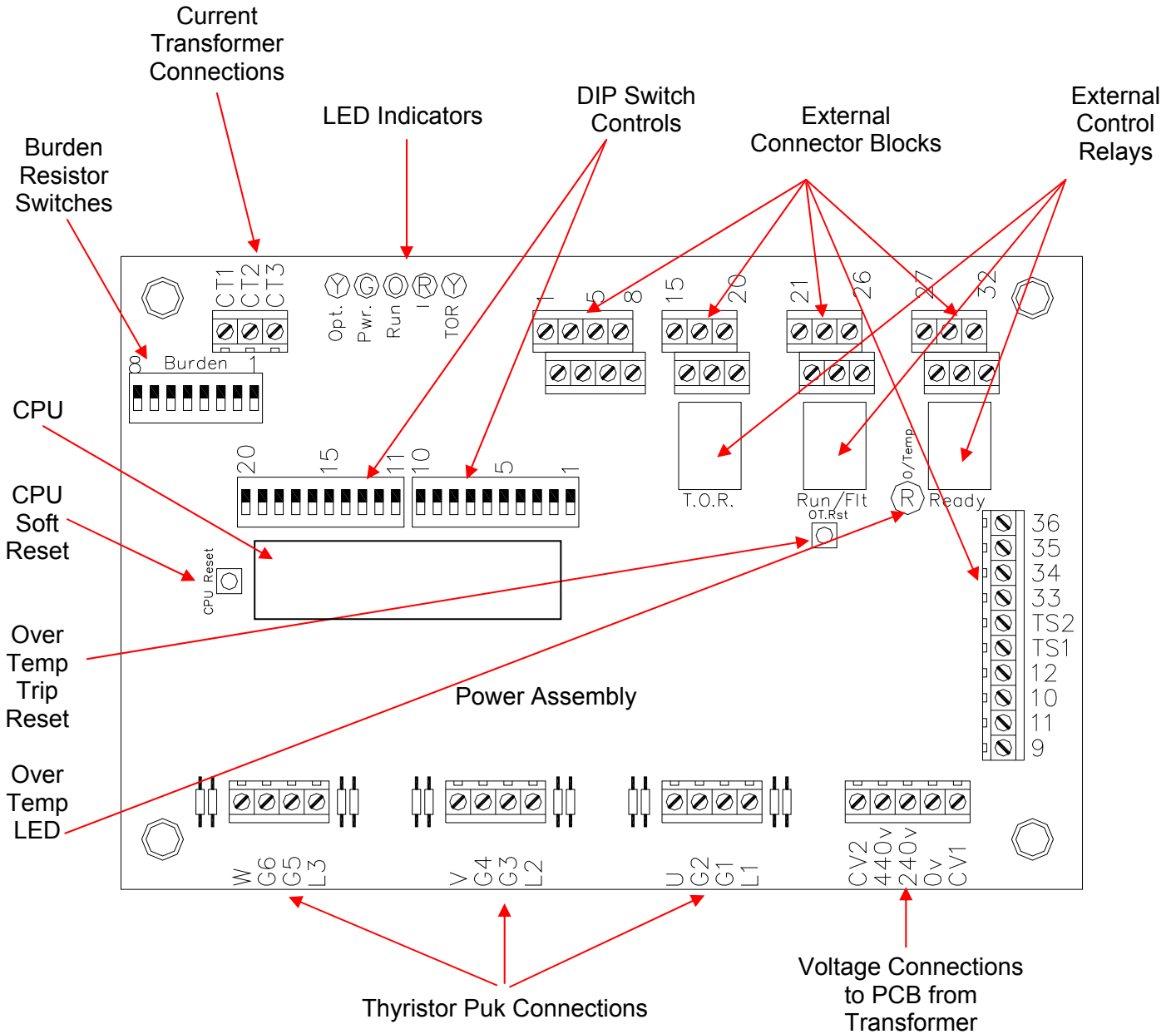

(See Appendix 5 on Page 48 for a photograph of this PCB)

5 USER CONTROL FEATURES

5.1 DEFAULT SETTINGS (2.2kW – 3.5kW)

The unit is set to the 'Default Settings' before leaving the factory. These should be tried first and further adjustments only made where necessary to 'fine tune' the **EnviroStart**.

ADJUSTMENT	FUNCTION	DEFAULT SETTING	RESULT	SEE SECTION
Switches 1 & 2	Start Ramp-Up Time	ON, OFF	Ramp Up at 10s.	6.2
Switches 3 & 4	Energy Saving Level	OFF & ON	Energy Saving Level at 40% of Full Power	6.4
Switch 5	Triac Fault Detection (Live Poll)	OFF	Fault Detection Enabled	6.5
Switches 6, 7 & 8	Start-Up Pedestal Voltage	ON, OFF, OFF	Set at 40% of Full Voltage	6.6
Switch 9	Soft-Stop Enable	OFF	Soft Stop is Disabled	6.7
Switch 10	Damping	OFF	Damping Enabled	6.9.1
L1 Link 1	50/60Hz Select	Link Closed	50 Hz Selected	6.8
L1 Link 2	Unassigned			
L1 Link 3	Unassigned			
L1 Link 4	Unassigned			
L1 Link 5	Energy Save Mode (Live Poll)	Link Open	Energy Saving Disabled	6.4
Potentiometer VR1	Current Limit (Live Poll)	Mid Rotation	Medium Power at Start of Ramp	6.12

(Relates to Software variants 8.8 and above)

SEE SECTION 5.11 FOR A DIAGRAM TO LOCATE THE ABOVE SWITCHES ON THE RELEVANT PCB.

Note that, except for switches and potentiometer marked "Live Poll" all switch changes will require that the EnviroStart CPU is reset either by powering the unit down or by using the CPU Reset button adjacent to the main processor for the changes to take affect.

DEFAULT SETTINGS - DIP SWITCH POSITIONS

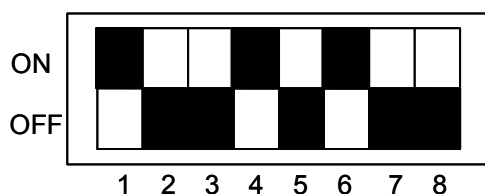

DEFAULT SETTINGS (5.5kW to 800kW)

The unit is set to the 'Default Settings' before leaving the factory. These should be tried first and further adjustments only made where necessary to 'fine tune' the **EnviroStart**.

ADJUSTMENT	FUNCTION	DEFAULT SETTING	RESULT	SEE SECTION
Switches 1, 2 & 3	Start Ramp-Up Time	OFF, ON, OFF	Ramp Up at 20s.	5.2
Switch 4	Start Time x4	OFF	No Multiplication	5.3
Switches 5 & 6	Energy Saving Level	OFF & ON	Set at 75% Full Power (Max Savings ≈ 25%)	5.4
Switch 7	Fault Detection (Live Poll)	OFF	Fault Detection Enabled	5.5
Switches 8, 9 & 10	Start-Up Pedestal Voltage	ON, OFF, OFF	Set at 40% of Full Supply Voltage	5.6
Switch 11	Soft-Stop Enable	OFF	Soft Stop is Disabled	5.7
Switch 12	50/60Hz Select	OFF	50Hz Selected	5.8
Switch 13 (Up to 8.8)	Thyristor Triggering Damping	OFF	Two Thyristors Firing	5.9.1
Switch 13 (After 8.8)		ON		Damping Enabled
Switch 14	Kick-Start Enable	OFF	Kick Start is Disabled	5.10
Switch 15	Kick-Start Level	ON	90% of Full Voltage	5.10
Switches 16 & 17	Kick-Start Time	ON & ON	Set at 0.25s	5.11
Switch 18 (≥Version 8.5 Only)	Emergency Run or Energy Save Disable (Live Poll)	OFF	Emergency Run Switchable on Connectors 5 - 8	5.4 & 5.21
Switch 19	Not Connected			
Switch 20	Energy Save Mode (Live Poll)	OFF	Energy Saving Disabled	5.4
Potentiometer VR1	Current Limit (Live Poll)	Mid Rotation	Medium Power at Start of Ramp	5.12

SEE SECTION 5.11 FOR A DIAGRAM TO LOCATE THE ABOVE SWITCHES ON THE RELEVANT PCB.

Note that, except for switches and potentiometer marked "Live Poll" all switch changes will require that the EnviroStart CPU is reset either by powering the unit down or by using the CPU Reset button adjacent to the main processor for the changes to take affect.

DEFAULT SETTINGS - DIP SWITCH POSITIONS

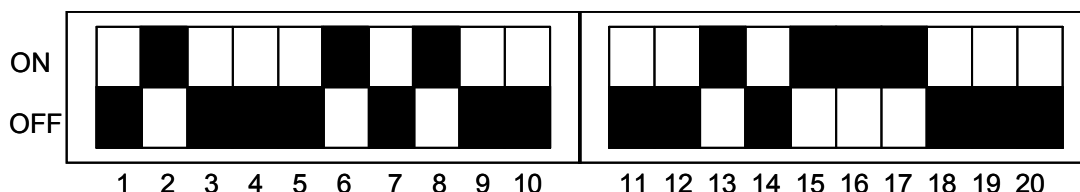

5.2 START UP RAMP TIME SELECTION

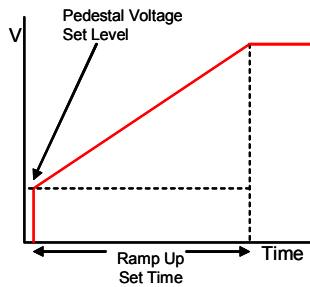

The Ramp-Up-Time switches 1, 2 and 3 adjust the time period from the initial pedestal setting to full output voltage. (See also Section 6.21 regarding the x4 multiplier function which is enabled by Switch 4).

2.2kW – 3.5kW switch settings as follows:

SWITCH 1	SWITCH 2	RAMP UP TIME
OFF	OFF	30s
OFF	ON	20s
ON	OFF	10s (Default)
ON	ON	5s

5.5kW to 800kW switch settings as follows:

SWITCH 1	SWITCH 2	SWITCH 3	RAMP UP TIME
OFF	OFF	OFF	60s
OFF	OFF	ON	30s
OFF	ON	OFF	20s (Default)
OFF	ON	ON	10s
ON	OFF	OFF	5s
ON	OFF	ON	2s
ON	ON	OFF	1s
ON	ON	ON	0.5s

5.3 RAMP TIME MULTIPLIER (5.5kW to 800kW Up To v8.9 Code)

This facility on DIP Switch 4, multiplies the ramp up time set by switches 1, 2 and 3, (and if enabled the ramp down) by a factor of 4 such that the start up ramp time can be extended to 240s and the soft stop ramp down to 192s, if soft stop is enabled.

On units with v8.10 or higher code DIP Switch 4 is used to switch the Phase Loss Detection circuits in and out of operation

5.4 ENERGY SAVING LEVEL SELECTION

Energy Control is enabled by L1 Link 5, (2.2kW – 3.5kW), or switch 20, (5.5 – 800kW units) on the main PCB; (also conditionally dependant on switch 18 and input at connectors 5 through 8). Energy saving starts 7.5s seconds after the motor has reached top of ramp. When enabled the yellow LED 1 flashes with a symmetric period to indicate that the energy control is working. If switch 20 is switched to the OFF position then LED 1 will be de-energised and energy saving will be disabled.

If required, (on systems with software variant 8.5 and above), energy saving can also be disabled and **EnviroStart** placed into full-power mode by putting switch 18 into the ON position and placing a logic 1, (closed contact), condition on terminals 5 through 8. This capability is useful if you have extremely high-load transient changes tending the controlled motor to stall; in such conditions, even though the **EnviroStart** reacts extremely fast, the controlled power-ramp, intrinsic within the control software, may be too long to accommodate the fast rise time of the load, resulting in the motor tending to stall and the “**EnviroStart**” shutting down as it would “see” a fault condition. In such circumstances you can use the control circuit that is sending the load change command to the motor-load, to disable energy save mode in **EnviroStart** and switch the unit to full power for the period of load change. This signal would always tend to be fractionally ahead of the motor “seeing” the load demand and as such, since the **EnviroStart** would immediately then provide full power, the motor would be “ready” for the load change to be placed on it. Additional to zero-volt hard wiring via a relay, the input circuit on connectors 5 through 8 is designed to accommodate, direct, NPN, (sink) or PNP (source) switching should it be necessary to switch directly from a PLC or other micro device. If energy saving is disabled in this way then, as with using switch 20, the yellow LED 1 will be de-energised. (Section 6.21 on p 41).

The **EnviroStart** saves energy by sensing how hard the motor is working and adjusting the power supplied to the motor accordingly providing sufficient torque to maintain synchronous rotation at all times, this is achieved by delaying the thyristor firing at each half-cycle, reduces voltage and current to the motor. Additional circuits manage the phase relationship between the voltage and the current waveforms. The maximum amount of saving allowed can be configured by adjusting the thyristor firing delay and can be set to maximise energy control according to the type of motor load. This saving level is adjusted using switches 5 and 6.

Where motors are running at low loading and are subject to gentle load changes it is possible to allow the **EnviroStart** to operate with maximum energy savings levels. Examples of applications of this type would include escalators, conveyor belts and most other similar highly geared loads. Where motors are subjected to high shock loads such as within injection moulding applications, energy control should be set to lower levels so the **EnviroStart** can respond rapidly without risk of stalling the motor. If any motor slow-down is noted when the load changes then you should decrease energy control settings by one level until this effect disappears, alternatively consider using selective energy control disabling using switch 18.

2.2kW – 3.5kW switch settings as follows:

SWITCH 3	SWITCH 4	Maximum Firing Delay % Volts	Approx Power	Energy Control*
OFF	OFF	30% (Nominal B/Stop 320V)	60% of Full Power	Maximum Saving 40%
OFF	ON	40% (Nominal B/Stop 350V)	75% (Default)	Median Savings 25%
ON	OFF	50% (Nominal B/Stop 370V)	85% of Full Power	Low Savings 15%
ON	ON	60% (Nominal B/Stop 400V)	95% of Full Power	Minimum Saving 5%

5.5kW – 800kW switch settings as follows:

SWITCH 5	SWITCH 6	Maximum Firing Delay % Volts	Approx Power	Energy Control*
OFF	OFF	30% (Nominal B/Stop 320V)	60% of Full Power	Maximum Saving 40%
OFF	ON	40% (Nominal B/Stop 350V)	75% (Default)	Median Savings 25%
ON	OFF	50% (Nominal B/Stop 370V)	85% of Full Power	Low Savings 15%
ON	ON	60% (Nominal B/Stop 400V)	95% of Full Power	Minimum Saving 5%

*The voltages given above are indicative only and may vary depending upon supply level

5.5 THYRISTOR & TRIGGERING FAULT DETECTION SELECTION

EnviroStart has an intrinsic thyristor fault detection programme running at all times during operation. The system software constantly monitors the correct firing and operation of the thyristors and will stop the system and register a fault condition in the event of a gate, a junction or a trigger pulse mode failure.

If the fault exists at the time that a start signal is applied to **EnviroStart** then the motor may start to turn if the initial phase drive is a functional thyristor pair, usually there will be no more than 90° rotation. By the time that the system starts to fire the second pair of thyristors the fault will have been detected, and the drive will be removed and the fault condition indicator will register with four quick flashes followed by a one second wait period on the yellow Fault LED. In the case of very low power factor motors it may be necessary to disable this detection circuit to eliminate erroneous fault indications.

2.2kW – 3.5kW switch settings as follows

SWITCH 5	THYRISTOR & TRIGGERING FAULT DETECTION
OFF	Detection Not Disabled (Default)
ON	Fault Detection Disabled

5.5kW – 800kW switch settings as follows

SWITCH 7	THYRISTOR & TRIGGERING FAULT DETECTION
OFF	Detection Not Disabled (Default)
ON	Fault Detection Disabled

5.6 START UP RAMP PEDESTAL VOLTAGE SELECTION

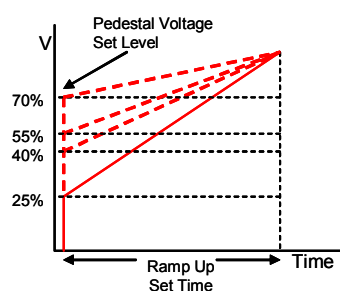

This sets the initial voltage that is applied to the motor. This is adjusted to a level so that the motor starts to accelerate smoothly and immediately.

It should normally not be necessary to adjust Pedestal voltage except where motors are started on-load with high loads. If there is a delay between start up and the motor starting to turn, increase the Pedestal Voltage until this disappears.

2.2kW – 3.5kW switch settings as follows:

SWITCH 6	SWITCH 7	SWITCH 8	PEDESTAL VOLTS STARTS AT
ON	ON	OFF	25 % of Full Voltage
ON	OFF	OFF	40 % (Default)
OFF	ON	OFF	55% of Full Voltage
OFF	OFF	OFF	70% of Full Voltage
OFF	OFF	ON	100% (DOL start)

5.5kW – 800kW switch settings as follows:

SWITCH 8	SWITCH 9	SWITCH 10	PEDESTAL VOLTS STARTS AT
ON	ON	OFF	25 % of Full Voltage
ON	OFF	OFF	40 % (Default)
OFF	ON	OFF	55% of Full Voltage
OFF	OFF	OFF	70% of Full Voltage
OFF	OFF	ON	100% (DOL start)

5.7 SOFT STOP ENABLE SELECTION (2.2kW – 800kW)

Switch 9, (2.2kW – 3.5kW) or 11, (5.5kW – 800kW), is used to enable the soft stop function of **EnviroStart**. The default condition is with the switch OFF, which is no soft stop. In the ON position soft stop is enabled, providing the motor with a controlled shut down function when motor is turned off using the run – stop control function on connector pins 7 and 8 (2.2kW – 3.5kW) or 1 through 4, (5.5kW – 800kW).

The ramp down time is defined by the time it would take the motor to be run to a stop from full power that is with full voltage applied. This is shown in the table below; the times are defined by the settings of the Start up Ramp as selected using switches 1 and 2 (2.2kW – 3.5kW) or 1, 2 and 3 (5.5kW – 800kW). There is no independent time selection within the Motor Energy Control software. The 2.2kW – 3.5kW unit times are shown shaded blue within the table. On the 5.5kW through 800kW systems the 4x time multiplier on switch 4 increases the stop time by a factor of four when ramp-up times of 5s or longer are selected.

When, soft stop is enabled by switch 9, (2.2kW – 3.5kW) or 11, (5.5kW – 800kW), and the start signal on connector pins 7 and 8, (2.2kW – 3.5kW), or 1 through 4, (5.5kW – 800kW), is removed, the **EnviroStart** control structure linearly decreases the voltage from the level being supplied at that time to the motor, to a voltage point which is determined by the power factor of the motor and the loading of the motor, this point is typically around 125V to 150V but will vary from motor to motor as a function of the line condition, supplied full voltage level and characteristics of the motor itself.

If the start signal on connector pins 7 and 8, (2.2kW – 3.5kW), or 1 through 4, (5.5kW – 800kW), is permanently removed then the motor will be controlled to a stop and the system will reset to a “ready” state with only power LED 2 lit. With switch 11 in the ON position, enabling soft stop, a momentary change of state on connector pins 7 and 8, (2.2kW – 3.5kW), or 1 through 4, (5.5kW – 800kW), will cause the soft stop to initiate and the motor to be powered down to a stop. In such circumstances, when the end of ramp-down is reached then the yellow LED 1 will start to flash twice separated by a 1s interval indicating that the end of ramp down has been reached. To restart the motor the system will need to reset by having the connector pins 7 and 8, (2.2kW – 3.5kW), or 1 through 4, (5.5kW – 800kW), made open circuit or logic 0.

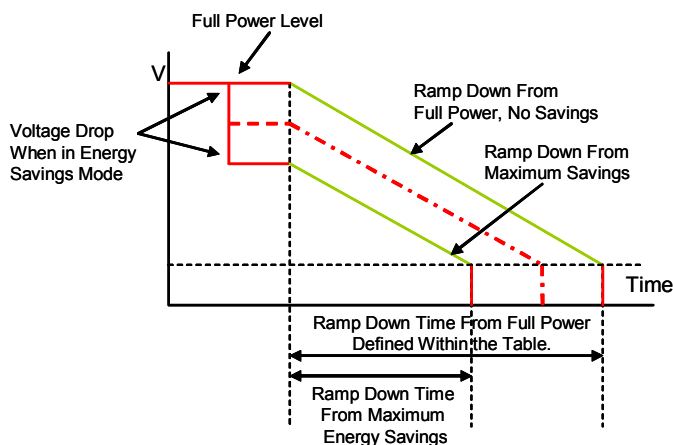

Ramp Up Time	Yields Stop Time
0.5s	5s
1.0s	5s
2.0s	5s
5.0s	5s
10s	8s
20s	16s
30s	24s
60s	48s

It is clear that if the EnviroStart is in energy saving mode then the ramp dV/dt will create a time period to bring the motor to a stop which is shorter than that which would be in place if EnviroStart was delivering full power at that time.

5.8 SUPPLY FREQUENCY SELECTION

This switch function should be set to reflect the supply frequency of the three-phase mains supply.

2.2kW – 3.5kW

LINK 1
Selects either 50Hz or 60Hz supply
Default is 50Hz (Link 1 Made)

5.5kW – 800kW

SWITCH 12
Selects either 50Hz or 60Hz supply
Default is 50Hz (Switch 12 OFF)

5.9.1 THYRISTOR TRIGGERING LEVEL SELECT (Up To v8.7 Code)

On certain types of motors the **EnviroStart** may not be able to drive the motor correctly when it is in energy saving mode causing the current supplied to the motor to become unstable as the feedback into the microprocessor falsely identifies that insufficient power is being applied to the motor for a given load. Changing the effective power envelope by changing the thyristor feed pattern may overcome this problem. By using switch 13 you can change the normal two thyristor trigger pattern to become a three thyristor trigger pattern eliminating the instability problem in many cases

This switch should not be enabled unnecessarily as there will be a reduction in energy savings.

2.2kW – 3.5kW switch settings as follows

SWITCH 10	TRIGGER PATTERN
OFF	Two Triacs Fired per Cycle (Default)
ON	Three Thyristors Fired per Cycle

5.5kW – 800kW switch settings as follows

SWITCH 13	TRIGGER PATTERN
OFF	Two of Six Thyristors Fired per Cycle (Default)
ON	Three of Six Thyristors Fired per Cycle

5.9.2 RESPONSE DAMPING SELECT (v8.8 Code Onward)

Motors under load with **EnviroStart** units fitted in energy saving mode, occasionally show instability at certain load levels, (whilst they are perfectly stable at other loads); to overcome this we have introduced a small level of damping to the response time of the unit. This has the effect of stabilizing the system across all load levels and also increasing the savings levels obtained at higher loads. The function is enabled by default and should only be disabled in cases where it is clear the motor is not responding quickly enough to load change demands.

5.5kW – 800kW switch settings as follows

SWITCH 13	DAMPING
OFF	Damping Disabled
ON	Damping Enabled (Default)

5.10 KICK START SELECTION (5.5kW to 800kW Only)

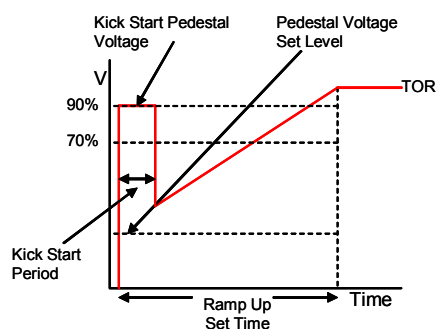

In some high stiction, high static friction or high torque loads, a better mechanical start can sometimes be achieved by using the Kick Start feature of **EnviroStart** to overcome the initial inertia of the load.

If the load is not of this type then this feature should not be used and switch 14 should be in the OFF position.

Switch settings as follows

KICK START ENABLE	Switch 14 enables Kick Start function when ON (Default is OFF)
KICK START LEVEL	Switch 15 sets Kick Start volts to 70% when OFF. 90% when ON (Default is ON at 90% of Full Voltage)

5.11 KICK START TIME DURATION (5.5kW to 800kW Only)

Switches 16 and 17 change the period that the kick start remains in place, allowing sufficient “kick” to be given to the motor to start effective rotation.

Switch settings as follows

SWITCH 16	SWITCH 17	KICK START DURATION
ON	ON	0.25s (Default)
ON	OFF	0.5s
OFF	ON	1s
OFF	OFF	2s

5.12 START UP CURRENT LIMIT SETTING (2.2kW to 800kW)

Motors started direct on line, (DOL), typically draw a peak starting current of about 8x their rated FLC.

In conjunction with the other control functions associated with the motor start as defined by a solid state control, such as ramp time and pedestal voltage, **EnviroStart** can be set to limit the starting current during this initial phase of the motor operation.

When the current limit potentiometer VR1, is turned away from its default condition of mid position then a variable degree of current limiting will be enabled which will extend from a maximum current excursion of approximately 5 - 8x motor FLC, when the potentiometer is fully anti-clockwise, to a limit value of approximately 1.5x motor FLC, when the potentiometer is fully clockwise. **EnviroStart** monitors the current drawn by the thyristors during ramp up, if the current exceeds the limit set by VR1 then the ramp is stopped and voltage held constant until the current falls below the preset limit, following which time the ramp up is continued. If the set current limit is reached during ramp up then the Red LED will light. It is not unusual during ramp up, particularly of larger motors, to see this LED flickering on and off.

30s after the start signal is applied to **EnviroStart** the current limit is released, (that is, if top of ramp has still not been reached at that stage); this is to ensure the smooth acceleration of the motor to full synchronous speed.

Current limit is useful in the management of the start of high inertia loads where supply restrictions may have placed limits on the maximum starting current allowed; (possibly because of supply cable or sub-station limitation).

For normal loads set VR1 between middle and fully clockwise to disable current limiting and provide maximum power to the motor defined by only the initial pedestal voltage and ramp period settings.

5.13 SYSTEM READY RELAY (Contacts 27 through 32) (5.5kW to 800kW Only)

This relay energises when power is applied to the **EnviroStart** and indicates that the PCB and all logic functions are operational. It is an indication of the system being available for operation and remains enabled throughout the running of the unit.

5.14 RUN/FAULT RELAY (Contacts 3 & 4 on 2.2kW to 3.5kW and Contacts 21 through 26 on 5.5kW to 800kW)

This relay energises when the start signal is applied to the **EnviroStart**. It does not indicate that the motor is at speed or running; just that there is a legitimate start signal applied to the control circuit. It can be used in reciprocal fashion to provide a fault indication if that is required.

When the control circuit, contacts 1 through 4, (5.5kW to 800kW) and contacts 7 and 8, (2.2kW to 3.5kW), are used to switch the motor on and off there is a 100ms delay between the time that the thyristors stop firing and the operation of the Run Relay, this allows this relay to be used to ensure that items like the Line Contactor are switched at near zero current rather than having them break at full power with the resultant arcing and contact damage that creates. If Soft Stop is enabled then this delay operates at the end of the ramp.

If the Soft Stop function is enabled, (Section 6.7), then the Run Relay changes state at the end of the soft stop period and **not** when the Start Signal is removed from Connection 1 – 4.

5.15 TOP OF RAMP RELAY (Contacts 15 through 20) (5.5kW to 800kW Only)

This relay energises when the motor the **EnviroStart** is controlling has reached top of ramp and is at synchronous speed. The logic does not allow this relay to operate until the ramp up time period as defined by switches 1, 2 and 3 has elapsed though on lightly loaded motors full speed may have been reached prior to this time. If soft stop is enabled then as the unit starts to ramp the motor down and the rotation moves from TOR this relay changes state.



Relay Configuration 2.2kW through 3.5kW

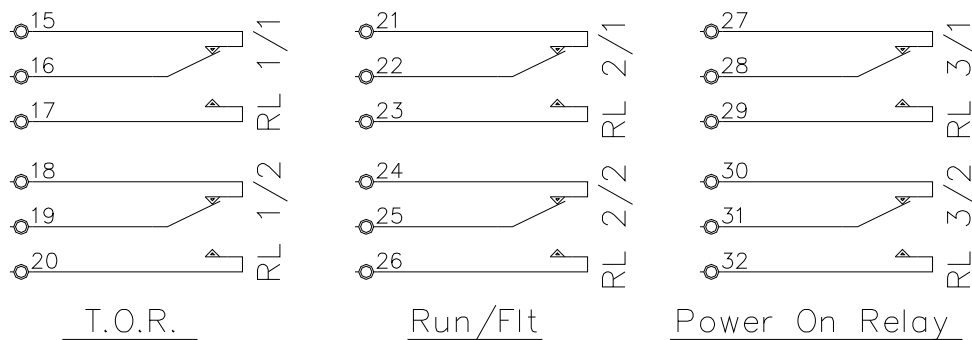

Relay Configuration 5.5kW through 800Kw

On the HPMEC/SS PCB's, (55kW units and above), a snubber has been placed across the contacts of the relays to reduce voltage spikes where higher powers are being switched. If a low power AC load is being switched by any of the relays, (such as a small current slave relay), then the "leakage" through the snubber can be sufficient to cause improper operation of that slave relay. (DC loads will not be affected). If this occurs then you can disable the snubber on that relay contact by making the series resistor within the RC network open circuit; do this by cutting the lead at one end of the resistor. (Do not attempt this if you are not certain what you are doing).

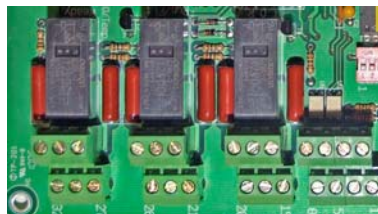

You can see the six RC pairs in the photograph above, each pair associated with one side of the double pole changeover in each relay.

5.16 OVER TEMPERATURE TRIP CONTROL (55kW to 800kW)

If the **EnviroStart** heatsink goes above 90°C, the heatsink over-temperature trip will open and turn off the **EnviroStart**. The thermal overloads themselves will automatically reset once the temperature drops below 70°C however the motor will not automatically restart until such time as the over temperature reset button on the PCB is made, or an external reset is provided on connectors 33 through 36.

Note that over temperature detection is not fitted to units of 2.2kW through to 37kW.

Over Temperature External Reset

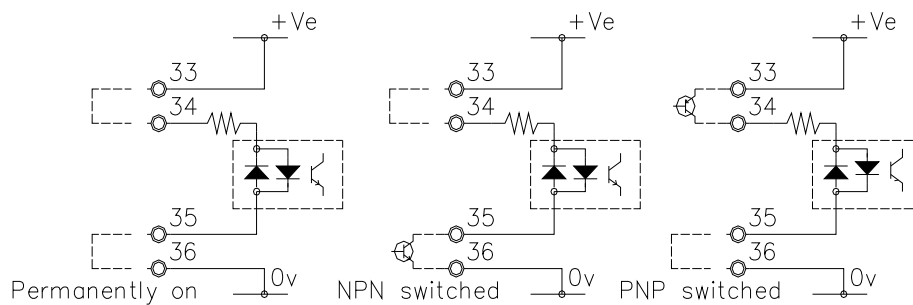

On **EnviroStart** units of 55kW and above an optional motor Thermistor/thermal trip interface circuit is available which will allow the integration of motor-temperature sensors into the **EnviroStart** control circuit.

With this circuit fitted and the motor temperature sensors linked into the **EnviroStart** control, either motor windings or the **EnviroStart** Thyristors going over their set temperature will cause the thermal trip to activate, safely shutting the system down prior to any damage being caused to either motor or **EnviroStart**.

Should you want this option then it must be specified at the time that your **EnviroStart** is ordered, this is not a feature that can be retrofitted once a system has been supplied

5.17.1 VOLTAGE SELECTION (2.2kW to 5.5kW)

WARNING: Please check these setting are correct before first starting the unit.

The 2.2kW to 3.5kW units are single voltage operation only. The voltage is determined as a factory fitted option and is not user changeable. (220V, 400V and 480V available).

5.17.2 VOLTAGE SELECTION (5.5kW to 800kW)

WARNING: Please check these setting are correct before first starting the unit.

All 220/400V units are shipped with the voltage set at 400V; 208/480V units are shipped with the voltage set at 480V. In the case of the 570V units, the voltage is set at 570V and in the case of 690V units, at 690V. (The two higher voltage units do not have multi-tap transformers fitted and are therefore fixed at the supplied voltage only)

On the 5.5kW through 37kW units should you require that the operating voltage of the unit be changed from 400V to 200V, (ROW), or from 480V to 208V, (USA), swap the position of the 400V and 220V marked push-on connectors found on the underside of the PCB. In the case of the 55kW through 800kW units make the same exchange of leads in the screw terminal connector block swapping the leads into the 220V and 400V connectors.

In the event that you wish to supply the LP PCB, (5.5kW though 37kW), from an external source then you should disconnect the supply leads from the PCB terminals and connect a

208V AC (USA), or 220V AC (ROW) supply between the lead that was on the 0V terminal and the lead that was on the 220V terminal. The lead that was on the 400V terminal could be “docked” safely on the 220V pin of the PCB, removed completely or insulated and secured elsewhere. (It is recommended that it be docked to the 220V terminal of the PCB as this is isolated and secure. In the event that you wish to supply the HP PCB, (55kW through 800kW), from an external source then this can be done by putting a 208V AC (USA), or 220V AC (ROW) supply onto CV1 and CV2 and by removing the two Fuse Links F1 and F2 which are immediately above the Power Connector terminal block.

WARNING: It is imperative that the fuse links on the PCB are removed if an external 208V (USA) or 220V (ROW) supply is used. (55kW through 800kW)

All units are supplied with a transformer suitable for use with the voltage you specified on your order. The fundamental requirement is that there be 10V AC fed to the PCB at connector pins 9 and 11. Should you require you can maintain the logic +5V DC on the PCB by providing between 7V and 24V DC on the 0V and +24V connectors 10 and 12.

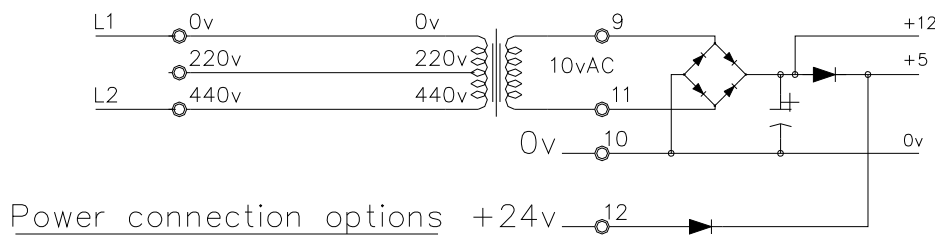

5.5kW through 37kW PCB Power Connections

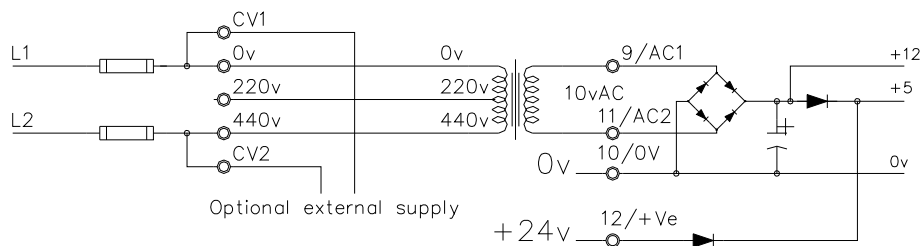

55kW through 800kW PCB Power Connections

5.18 STALLED-ROTOR OVER-CURRENT PROTECTION (2.2kW to 800kW)

The system software is capable of detecting the lack of synchronous rotation in the motor the **EnviroStart** is driving. In such an event the software will check the status functions of all the outputs and if they are found to be satisfactory then it will assume that the rotor is stalled or being stalled in some manner and in order to protect the system and the motor it will shut down the feed current eliminating the possibility of motor burn out.

In the event of the system stopping in this way the motor should be checked and free rotation ensured before such time as the unit is restarted. The **EnviroStart** will need to be reset when it has stopped in this way, this can be done by either powering the system down or by pressing the restart button on the PCB.

Before resetting the **EnviroStart** and restarting the motor always ensure that the motor is safe to operate.

Note that the stalled rotor function detection function within **EnviroStart** cannot replace an effective, properly rated current-overload fitted within the supply circuit and will never provide full protection against catastrophic mechanical collapse of the motor such as when a bearing fails and/or the rotor goes short to the stator. In these cases the current and voltage spikes are too high and too fast for the **EnviroStart** to react, peaking as they would in a matter of a few hundred nanoseconds.

5.19 INTEGRAL COOLING FAN CONNECTIONS

All **EnviroStart** units of 30kW and above are fitted with integral cooling fans; in units manufactured up to December 2005 these have to be independently powered with either an 110V AC or 220V AC supply. It is important that the fans are running at all times that the unit is operating. On 30kW and 37kW systems the fan supplies are made direct onto the single fan that is fitted using insulated Lucar type connectors, on the 55kW through 110kW the connection for the integrated twin fans will be made onto a marked connector block adjacent to the PCB mounted on the backplane of the system. On systems of 132kW and above the fans are dual voltage and should be connected as shown below.

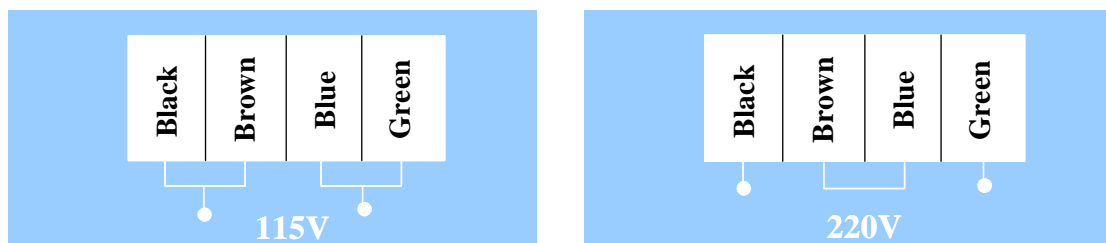

It is very important that only the voltage appropriate to the fan be used otherwise the fans will be damaged which may cause overheating of the **EnviroStart** unit. Always check the fan voltage rating and or connection schema before powering the fans for the first time.

EnviroStart units of 30kW through to 150kW, manufactured from January 2006 onwards, will have their fans self powered; an additional feed being taken from the incoming supply, via a separate transformer through the Run Relay on pins 25 and 26, (Section 6.14), to the fans input. The purpose of running the feed through the Run Relay is to ensure that the fans are operating only at times when the unit is powered and driving a load. If it is required that the fans be running at all times that the unit is powered, because of high ambient temperature environments, (average ambient $\geq 25^{\circ}\text{C}$), then this can be achieved by moving the wires running into the Run Relay I/O on pins 25 and 26 and placing them into the System Ready Relay I/O on pins 31 and 32, (Section 6.13).

On systems of 186kW and above the fans will be wired as above to a four way connector block and an externally transformer supplied which should be mounted, in a convenient nearby location. A feed will have to be taken from the connector block to the transformer and then back from the transformer to the connector block to feed the fans. The reason for approaching the fan feed in this way is that it allows the safe positioning of the fan supply transformer away from the bus bars and **EnviroStart** power circuits. Appropriate cabling of suitable current rating should be used for the feed and supply and care should be taken noting that the feed from the connector block will be at the three phase RMS voltage of the unit.

5.20.1 START AND STOP FUNCTION (2.2kW – 3.5kW)

The controlled motor is started and stopped by making contact between connector pins 7 and 8 on the PCB. This is a zero voltage contact set. It is important that no control current or voltage be fed to these terminals as this will result in damage to the control microprocessor.

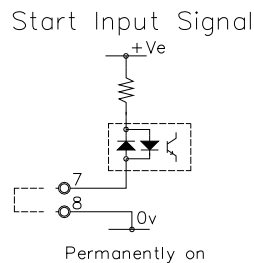

5.20.2 START AND STOP FUNCTION (5.5kW – 800kW)

The controlled motor is started and stopped by making contact between connector 1 and 3 on the PCB, when there is a permanent link between connector 2 and 4. This is a zero voltage contact set. It is important that no control current or voltage be fed to these terminals as this will result in damage to the control microprocessor.

The input circuit is capable of handling both direct start, having connector pins 2 and 4 linked and then making the link between connector pins 1 and 3 either via a switch or so that the motor starts on power being supplied or from a logic high, (source) or logic low, (sink) from a PLC system.

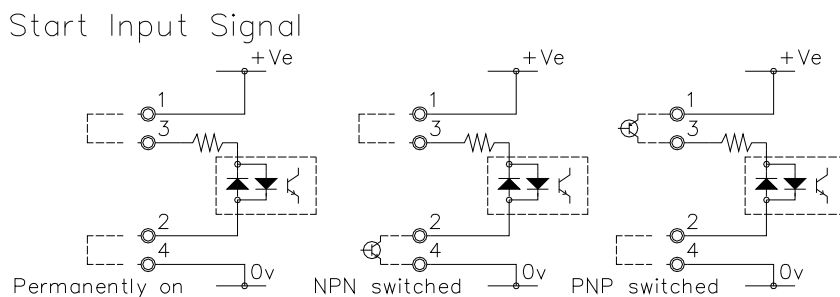

Start Function 5.5kW through 800kW

5.21.1 EMERGENCY RUN FUNCTION (2.2kW to 3.5kW)

In the event of certain control circuit failures it is possible to force all the Triacs into full permanent conduction allowing the motor to start and run direct on line, (DOL). This feature is enabled when connectors 5 and 6 are linked. In this condition it is not necessary to have a start signal, (closed circuit condition), on connectors 7 and 8.

Note that this function cannot be used if there is a failure of any of the Triacs or a failure of the **EnviroStart** drive circuit as the power pathway will be seen as open circuit.

When operating in this state, the yellow LED 1 illuminates aperiodically, flashing three times in quick succession followed by an off period of twice the on period of the three flashes. It is not recommended that units be left operating in the emergency run condition for any extended period of time however periods of up to 336 hours are acceptable.

During the time that the unit is operating in emergency run you should expect the system to generate greater heat than it would during normal operation, this is to be expected as the triacs are firing continuously.

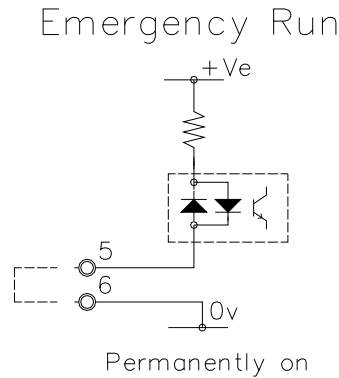

Start Function 2.2kW through 3.5kW

5.21.2 EMERGENCY RUN FUNCTION (5.5kW to 800kW)

In the event of certain control circuit failures it is possible to force all the Thyristors into full permanent conduction allowing the motor to start and run as though direct on line, (DOL). This feature is enabled when connectors 6 and 8 are linked and connectors 5 and 7 are also linked, assuming that the conditional switch 18 is in the OFF, (default setting, software versions 8.5 and above), position. In this condition it is not necessary to have a start signal on pins 1 through 4.

Note that this function cannot be used if there is a failure of any of the Thyristors or a failure of the **EnviroStart** drive circuit as the power pathway will be seen as open circuit.

In this condition the yellow LED 1 illuminates aperiodically, flashing three times in quick succession followed by an off period of twice the on period of the three flashes. It is not recommended that units be left operating in the Emergency Run condition for any extended period of time however periods of up to 336 hours are acceptable.

In emergency run the TOR, (Top of Ramp), relay enables and changes state 2.8s after the start signal has been applied to connector pins 5 through 8.

During the time that the unit is operating in emergency run you should expect the system to generate greater heat than it would during normal operation, this is to be expected as the Thyristors are firing continuously. In this condition it may also be noticed that there is a high frequency whistle from the Thyristor Packs, (units up to 110kW), this is perfectly normal and should not be a cause of concern.

The drive for this function both direct start, having connector pins 7 and 8 linked and then making the link between connector pins 5 and 6 either via a switch or permanently so that the motor starts on power being supplied or from a logic high, (source) or logic low, (sink) from a PLC system. Additional to zero-volt switching across connectors 5 and 7 with connectors 6 and 8 linked, the input circuit on connectors 5 through 8 is designed to accommodate, direct, NPN, (sink) or PNP (source) switching should it be necessary to switch directly from a PLC or other micro device.

Emergency Run/Energy Save Disable Initiate

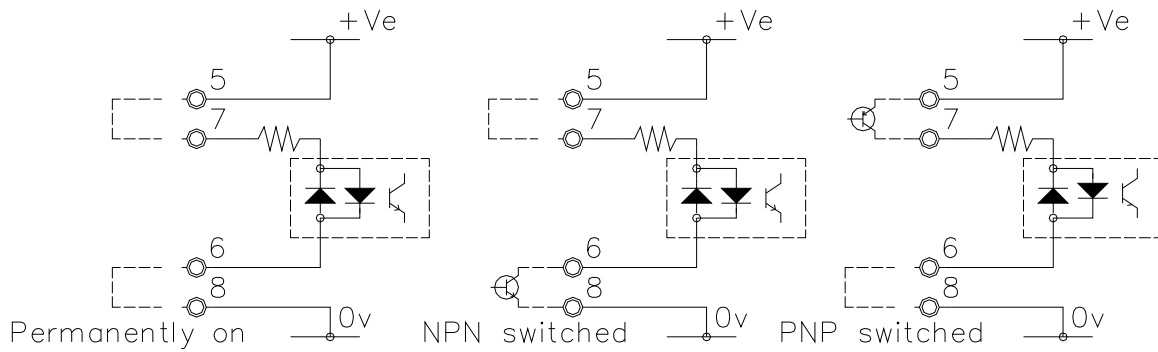

Emergency Run Function

5.22.1 PHASE LOSS DETECTION (2.2kW – 800kW Up to v8.8 Code)

As part of its power-up system integrity checks the **EnviroStart** software evaluates the continuity of both input supplies and also feeds to the motor and reports any functional phase or continuity loss with the yellow LED 1 flashing five times followed by a 1s period. (It should be remembered that normally, the control PCB of the **EnviroStart** is powered, via a transformer, from two of the input phases and as such if one of these phases is missing then the PCB will remain un-powered and no feedback will be given).

Once the system is driving a motor it is not possible to detect a phase loss on the input, (supply to the **EnviroStart**), if the two PCB supply phases remain intact, in such circumstances the motor may continue to run. If a phase loss occurs on the feed to the motor, during normal run then the system will shut down and report a thyristor fault condition with the yellow LED 1 flashing four times followed by a 1s period. This change of report function is created because the **EnviroStart** sees this lack of continuity to the motor as a simple inability to fire the thyristors and as such reports it in that way rather than the perceived secondary possible problem which is just that the connection to the motor has been lost.

5.23.1 LED INDICATORS (2.2kW – 800kW Up to v8.8 Code)

LED 1	Ramp Up Energy Saving Mode End of Ramp Down Emergency Run Thyristor Fault Phase Loss	<ol style="list-style-type: none"> 1. Illuminates constantly during ramp up, goes off at TOR. (Section 5.2) 2. Flashes synchronously to indicate EnviroStart is in Energy Saving mode. (Section 5.4) 3. Flashes twice separated by 1s period indicating that the unit has reached the bottom of a Soft Stop ramp. (Section 5.7) 4. Flashes three times separated by a 1s period if Emergency Run is enabled. (Section 5.21) 5. Flashes four times separated by a 1s period if a thyristor fault is detected. (Section 5.5 and 5.22) 6. Flashes five times separated by a 1s period if a phase loss is detected on power up. (Section 5.22)
LED 2	Power On	Illuminates when unit is powered and ready to operate, indicates that initialisation self test has been completed
LED 3	Run	Illuminates when a legitimate start signal has been received by the control circuit. This LED does not indicate that the motor is turning
LED 4	Current Limit	Illuminates when line current is at the set current limit level. This LED will flash intermittently during start when Current Limit is set below Full Power on VR1
LED 5	Top Of Ramp	Illuminates when motor is at full speed, this LED can only come on after ramp time set by switches 1, 2, 3 and 4

INSTALLATION AND COMMISSIONING GUIDE
END

Appendix 1

Mechanical Drawing 2.2kW – 3.5kW (220V & 400V)

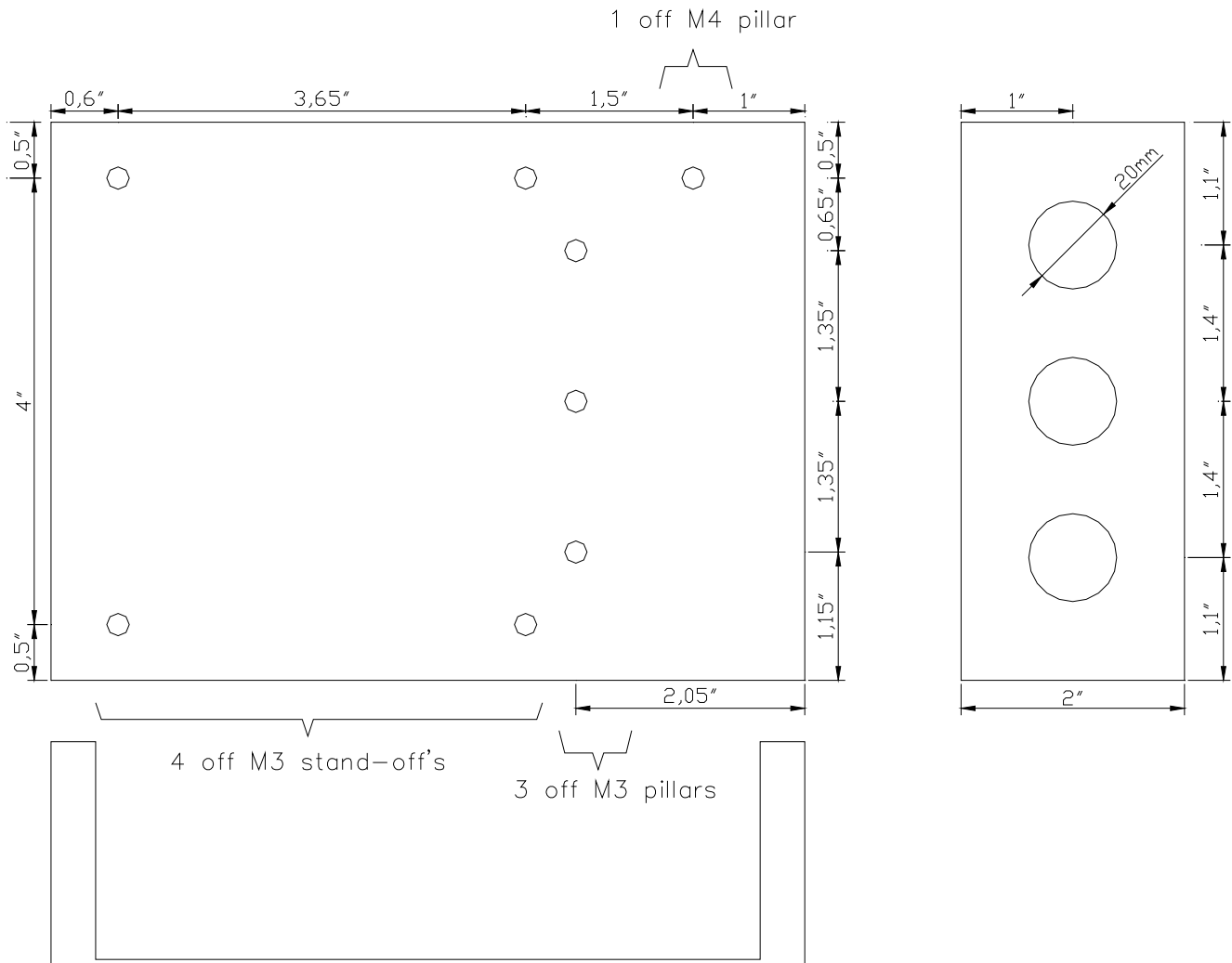

Mechanical Drawing 5.5kW – 37kW (220V & 400V)

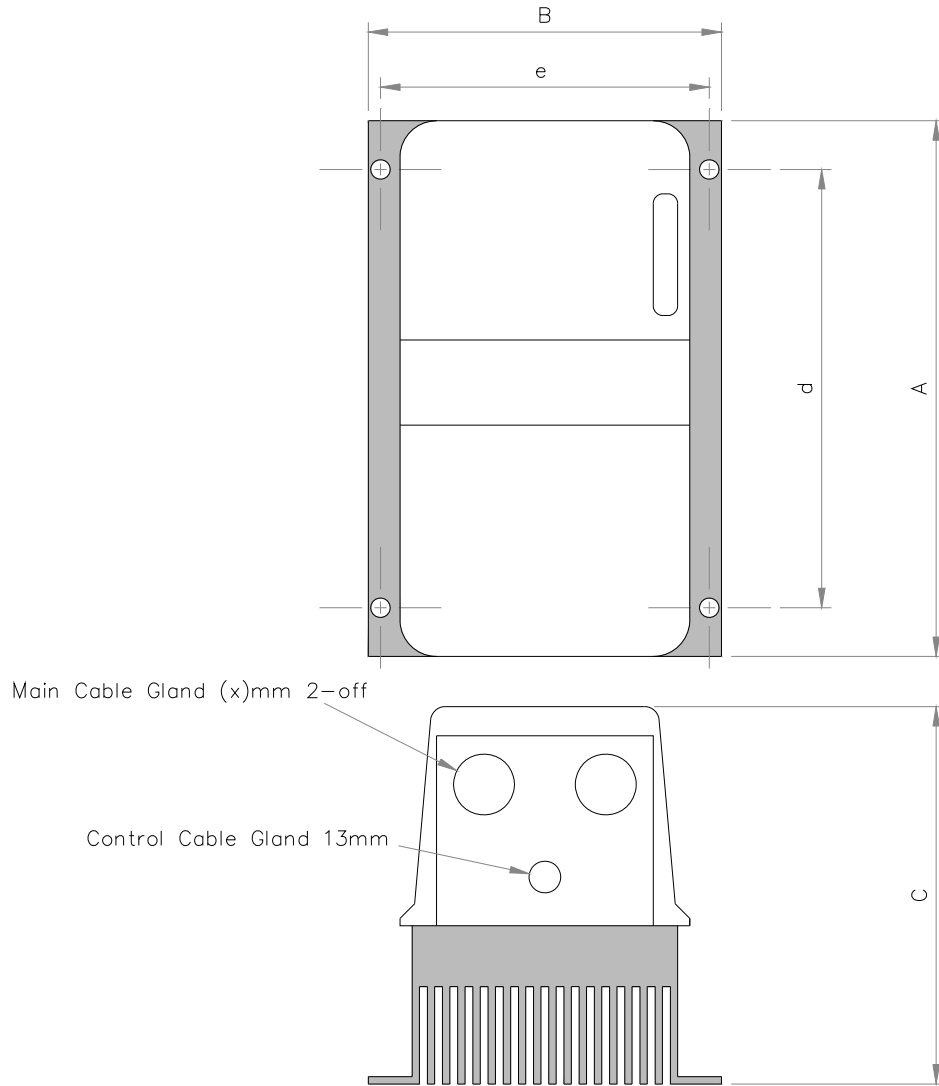

MODEL	A	B	C	d	e	x	Earth	Fixing Hole	Mains Connections
5.5–7.5kW	220	145	155	180	135	25	5	5.5	M5
11–22kW	220	145	175	180	135	25	5	5.5	M5
30–37kW	330	145	175	180	135	25	5	5.5	M5

Mechanical Drawing

5.5kW – 110kW (208V, 480V, 570V & 690V)
 55kW – 110kW (220V & 400V)

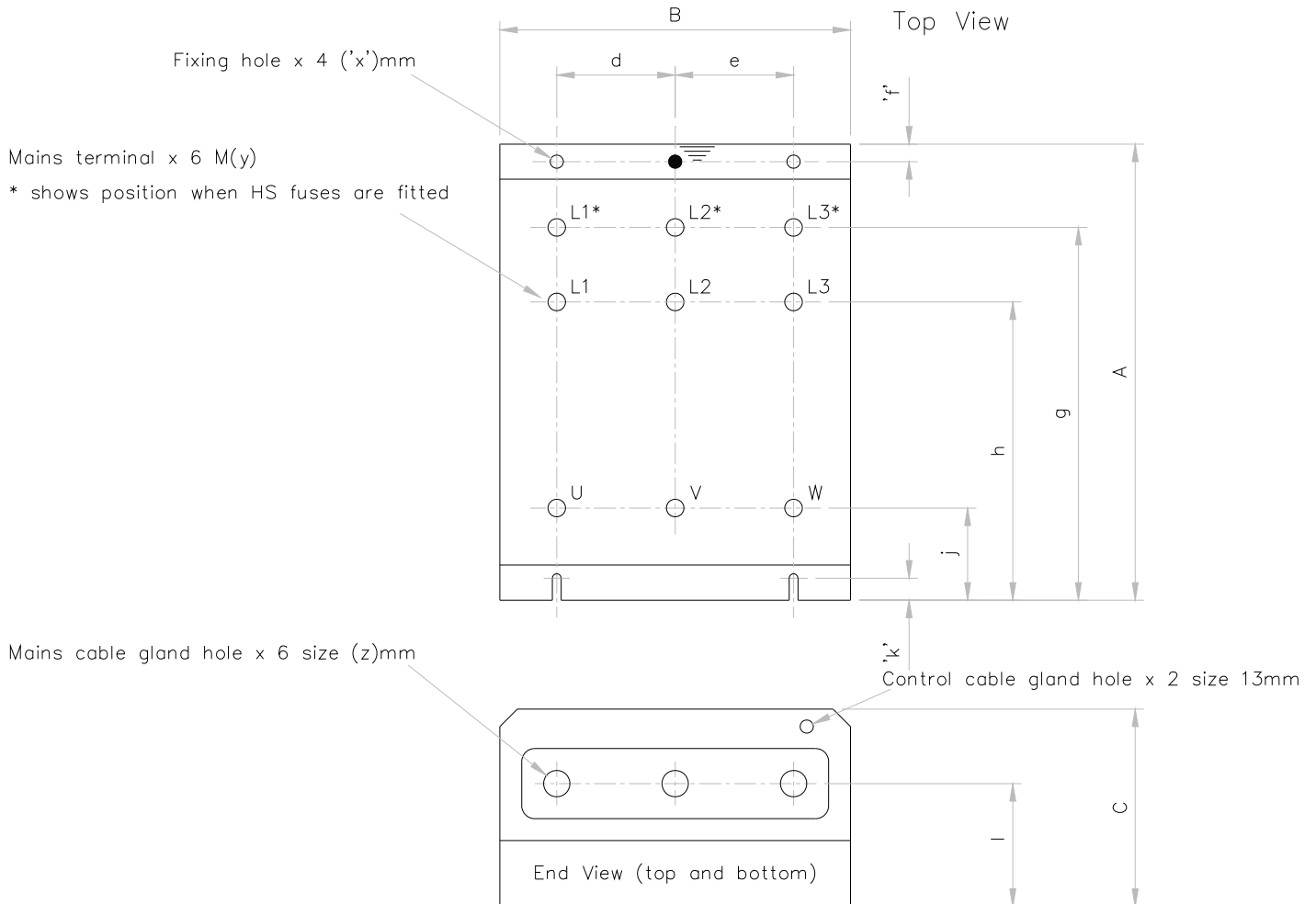

MODEL	A	B	C	d	e	f	g	h	j	k	l	x	y	z	Earth
30-37kW HV	430	254	280	70	70	7	351	271	65	10	78	6	8	30	6
55-110kW	430	254	280	70	70	7	351	271	65	10	78	6	8	30	6

The dimensions below only relate to the 208V, 480V, 575V and 690V HV units

5.5-22kW HV	325	164	195	50	50	7	250	198.5	65	10	78	6	8	30	6
-------------	-----	-----	-----	----	----	---	-----	-------	----	----	----	---	---	----	---

Note – Height of L1, L2, L3, L1*, L2*, L3*, U, V, W corresponds to l
 All dimensions in mm

Mechanical Drawings

132kW – 375kW

(208V, 220V, 400V, 480V 575V & 690V)

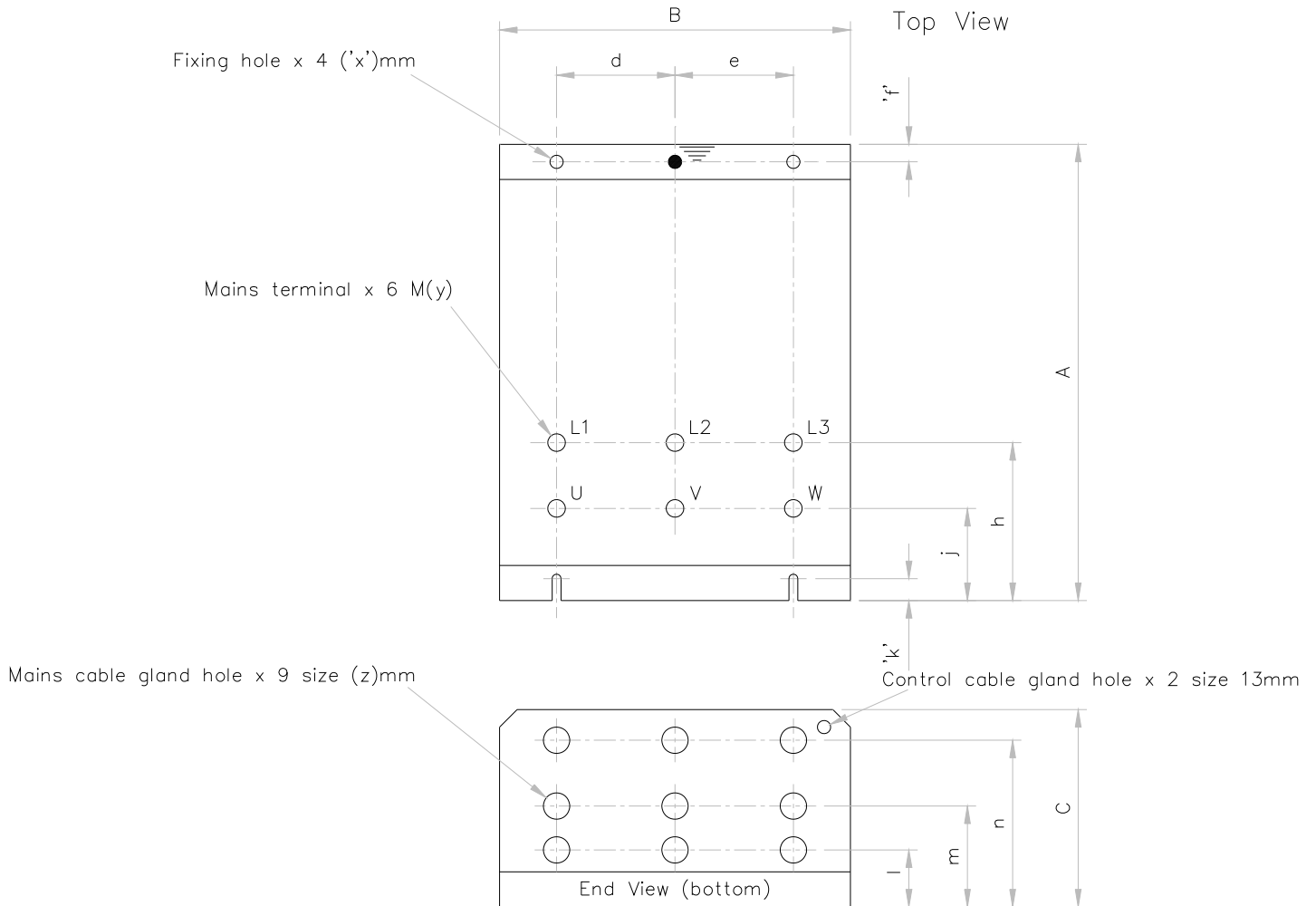

All dimensions in mm

MODEL	A	B	C	d	e	f	h	j	k	l	m	n	x	y	z	Earth
132–225kW	580	368	228	116	116	8	118	90	10	56	101	168	8	2 x 8	30	8
260–375kW	720	462	253	135	135	8	133	101	10	68	120	195	8	2 x 8	40	8

Note – Height of L1, L2, L3 without fuses corresponds to m, with fuses n, U, V, W corresponds to l

Mechanical Drawings

450kW – 800kW

(208V, 220V, 400V, 480V 575V & 690V)

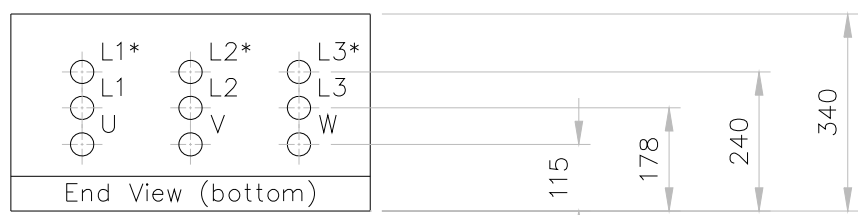
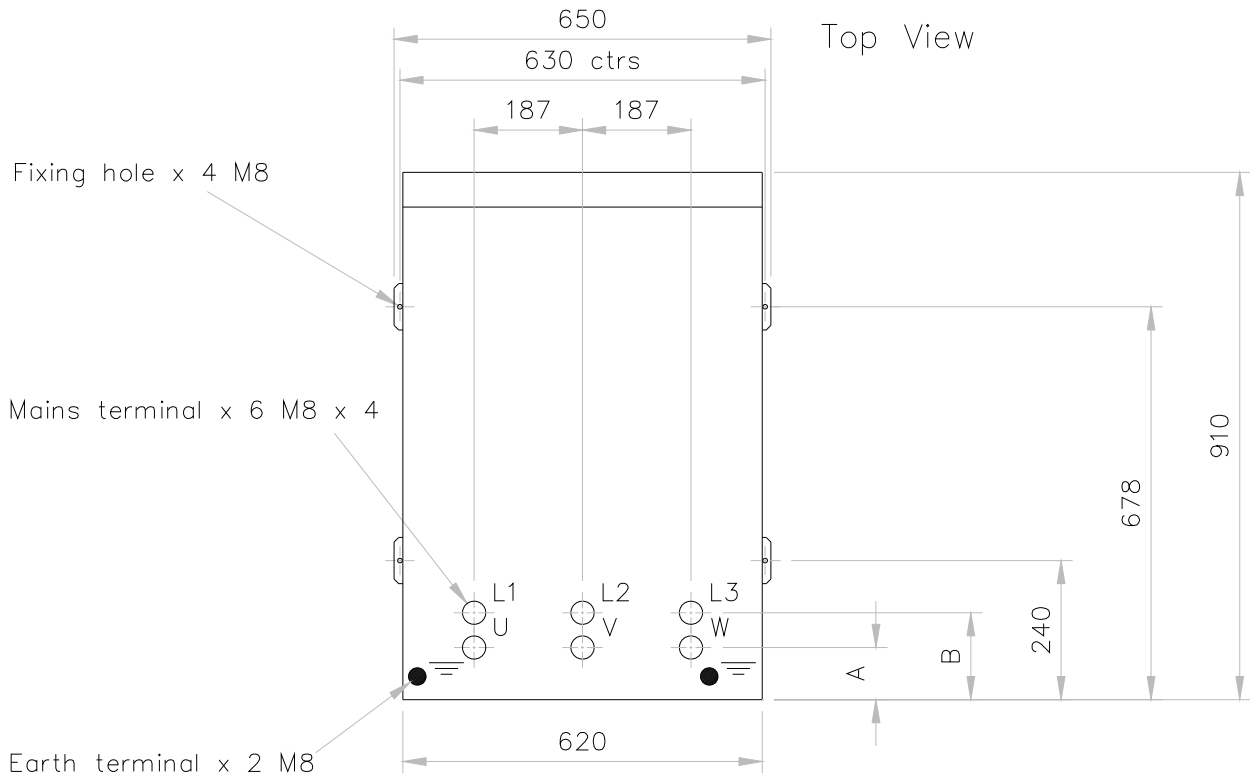

L1*, L2*, L3* show position when fuses are fitted

MODEL	A	B
450–500kW	150	90
630–800kW	90	150

Appendix 2

THE TESTING, REPLACEMENT AND ASSEMBLY OF THYRISTORS

Thyristor Short Circuit Test

With the gate/cathode connections disconnected from the control PCB measure the resistance between the input and the output of each phase of the power assembly in turn and in both directions, (positive to negative and negative to positive). A healthy reading will be in excess of 100k Ω . Any short circuit thyristors should be replaced. Care must be taken to re-connect the gate and cathode connections correctly.

Thyristor Gate-Cathode Test

With the gate and cathode leads disconnected from the control PCB measure the resistance between the two leads. This should be between 7 Ω and 60 Ω . If the meter reads open circuit first check the cable continuity and the crimp connectors on the device. Any open circuit thyristor should be replaced.

Thyristor Removal

Up to 110kW the power assemblies on the Soft Starters and Motor Energy Controls use isolated two-thyristor Pak devices. These devices are manufactured, as an anti-parallel pair so must be changed complete.

In power assemblies of 132kW and above individual hockey-puck devices are sandwiched between two aluminium heatsinks. Each thyristor is clamped by two fixing bolts, with a centre bolt compressing spring washers in order to give an indication of correct clamping tension. The centre bolt is not a fixing bolt its only purpose is to set the tension on the spring loaded washers so when the fixing bolts are tightened to the correct torque the centre tab washer is freed. The torque setting on the centre bolt is factory set under no circumstances should be loosened or the torque setting on the spring washers will be lost.

When dismantling, the two fixing bolts should be loosened evenly. Note the polarity of the devices, they are an anti-parallel pair and should be replaced as such.

Power Assembly, Re-assembly of Pak Devices

Re-assembly of the power assemblies using Pak devices is very simple. Smear a small amount of heatsink compound onto the base of the new device before fixing. Torque settings are as below.

Size of Unit	Thyristor to Heatsink	Pak Screw Terminals
5.5 – 37kW	2.5 – 4.0Nm	2.5 – 4.0Nm
55 – 63 kW	2.25 – 2.75Nm	4.5 – 5.5Nm
75 – 110kW	2.5 – 5.0Nm	12 – 15Nm

Power Assembly, Re-assembly, Puck Devices

Connect the gate and cathode leads to the new device. Smear the top and bottom of the new device with a small amount of heatsink compound that must be electrically conductive. Fit the device on the lower heatsink taking care that the device is the correct way around and is fitted correctly on the location pin. Fit the top heatsink, similarly ensuring correct location of the pin, and tighten the two fixing bolts evenly until correct torque is achieved, this happens when the spring washers compress enough to just loosen the tab washer under the centre nut.

Hockey Puck' Stack Assembly

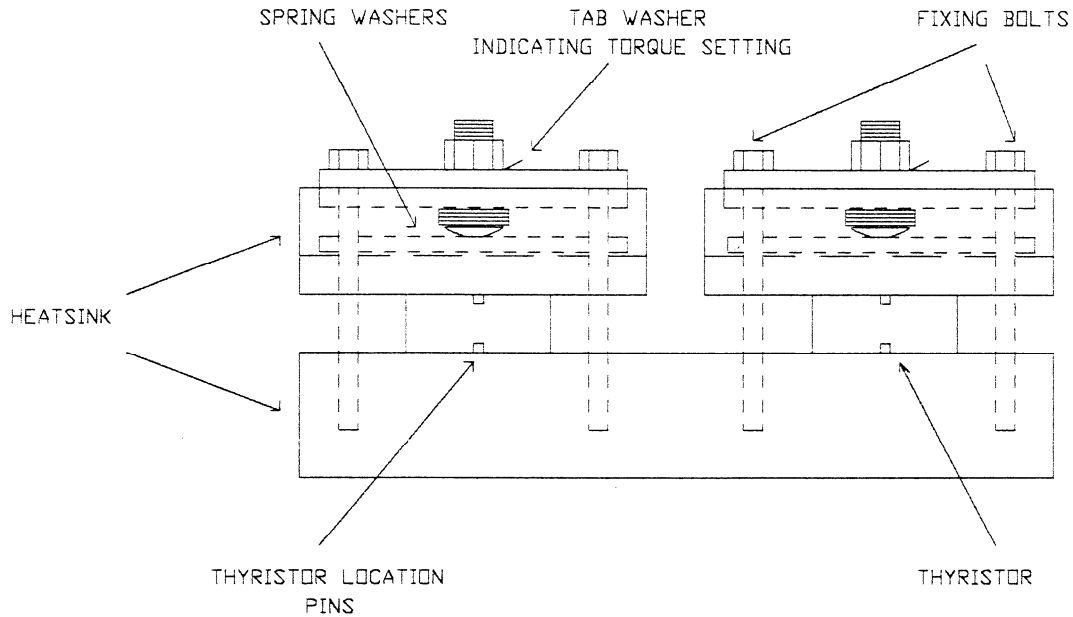

Note - the thyristors should be re-connected as follows:

- G1 - U
- G2 - L1
- G3 - V
- G4 - L2
- G5 - W
- G6 - L3

Control PCB

The control PCB is the least likely item to develop a fault and should only be suspected if all other avenues of investigation concerning the fault have proven negative. Faulty PCBs should be returned to the manufacturer for repair or replacement, as there are no user serviceable parts on the PCB.

THYRISTORS USED IN ENVIROSTART PRODUCTS 220V & 400V, 5.5kW to 800kW

PART No.	THYRISTOR TYPE IXYS	AMPS @ T _{case} 85°C	Q T Y	PART No.	THYRISTOR TYPE WESTCODE	AMPS @ T _{heatsink} 85°C	Q T Y
TPMEC - 5.5	MCC19-14io1	18	3	TPMEC - 132	N0782-YS140	530	6
TPMEC - 7	MCC26-14io1	27	3	TPMEC - 150	N0782-YS140	530	6
TPMEC - 11	MCC56-14io1	60	3	TPMEC - 186	N1265-LS140	835	6
TPMEC - 15	MCC56-14io1	60	3	TPMEC - 225	N1265-LS140	835	6
TPMEC - 22	MCC95-14io1	116	3	TPMEC - 260	N1265-LS140	835	6
TPMEC - 30	MCC95-14io1	116	3	TPMEC - 315	N1802-NS140	1216	6
TPMEC - 37	MCC95-14io1	116	3	TPMEC - 375	N1802-NS140	1216	6
TPMEC - 55	MCC162-14io1	181	3	TPMEC - 450	N2046-NS140	1338	6
TPMEC - 63	MCC162-14io1	181	3	TPMEC - 500	N2500-VC140	1684	6
TPMEC - 75	MCC220-14io1	250	3	TPMEC - 630	N2500-VC140	1684	6
TPMEC - 90	MCC250-14io1	287	3	TPMEC - 800	N4085-ZC120	2743	6
TPMEC - 110	MCC310-14io1	320	3				

Appendix 3

GENERAL SPECIFICATION

MODEL	CURRENT	kW @ 220V	kW @ 400V	kW @ 575V	kW @ 690V	WEIGHT kg	CT Specified	CT Ratio	FANS
TPMECG6- 2.2	5.5	1.2	2.2	3	3.75	.750	N/A	N/A	N/A
TPMECG6- 3.5	9	2	3.5	5	6	.750	N/A	N/A	N/A
TPMECG6- 5.5	11	2.2	5.5	6	7.5	2	LA2100	1000/1	N/A
TPMECG6- 7	16	4	7.5	9	11	2	LA2100	1000/1	N/A
TPMECG6- 11	23	5.5	11	13	15	3	LA2100	1000/1	N/A
TPMECG6- 15	30	7.5	15	18.5	22	3	LA2100	1000/1	N/A
TPMECG6- 22	45	11	22	26	30	3	LA2100	1000/1	N/A
TPMECG6- 30	60	15	30	37	45	4	LA2100	1000/1	1 X 120mm
TPMECG6- 37	75	22	37	45	55	4	LA2100	1000/1	1 X 120mm
TPMECG6- 55	105	30	55	63	75	15	LA2100	1000/1	2 x 120mm
TPMECG6- 63	120	37	63	75	90	15	LA2108	2000/1	2 x 120mm
TPMECG6- 75	145	45	75	90	110	15	LA2108	2000/1	2 x 120mm
TPMECG6- 90	170	55	90	110	132	16	LA2108	2000/1	2 x 120mm
TPMECG6- 110	205	63	110	132	150	16	LA2108	10000/1	2 x 120mm
TPMECG6- 132	255	75	132	150	186	28	TX008	10000/1	3 x 120mm
TPMECG6- 150	290	90	150	186	225	28	TX008	10000/1	3 x 120mm
TPMECG6- 186	340	110	186	225	260	28	TX008	10000/1	3 x 120mm
TPMECG6- 225	412	132	225	260	315	28	TX008	10000/1	3 x 120mm
TPMECG6- 260	475	150	260	315	375	45	TX008	10000/1	3 x 150mm
TPMECG6- 315	580	186	315	375	450	45	TX008	10000/1	3 x 150mm
TPMECG6- 375	670	215	375	450	500	45	TX008	10000/1	3 x 150mm
TPMECG6- 450	800	260	450	500	630	120	TX009	10000/1	2 x 220mm
TPMECG6- 500	900	315	500	630	750	120	TX009	10000/1	2 x 220mm
TPMECG6- 630	1100	375	630	750	900	120	TBA	TBA	2 x 220mm
TPMECG6- 800	1400	450	800	900	1200	120	TBA	TBA	2 x 220mm

The kW ratings are all based on calculations scheduled with a standard four-pole motor operating at a nominal T_{ambient} of +20°C at sea level. All units should be selected based on the current rating of the motor to which they are fitted.

Appendix 4

FAN SPECIFICATION

Papst Part No.	GD Rectifier Part No.	EnviroStart Size	Free Air Flow Rate	Physical Size
4600N/4650N	550010A/ 550010B	30kW - 225kW	160 m ³ /hour	120 mm
7400N/7450N	550006A/550006B	260kW – 375kW	350 m ³ /hour	150 mm
N/A	550002A /550002B	450kW – 800kW	900 m ³ /hour	220 mm

Should you need to change any of the fans within your **EnviroStart** system please ensure that units compatible with the above are used. It is not possible to exchange fans for units of different physical size without damaging the **EnviroStart** unit.

Appendix 5

HP – kW CONVERSION

HP - kW Conversion

HP Std	Amps	kW @ 120V	kW @ 220V	kW @ 400V	kW @ 570V	kW @ 690V
Single Phase						
1.5	4	0.5	1	N/A	N/A	N/A
3	10	1	2	N/A	N/A	N/A
5	15	1.6	3	N/A	N/A	N/A
Three Phase						
7.5	12	N/A	2.2	5.5	6	8
10	16	N/A	3.5	7.5	9	11
15	23	N/A	5.5	11	11	15
20	30	N/A	7.5	15	15	18.5
25	37	N/A	7.5	18.5	18.5	22
30	45	N/A	9	22	22	30
40	60	N/A	11	30	30	37
50	75	N/A	15	37	37	45
75	95	N/A	22	55	55	63
100	145	N/A	30	75	75	90
125	170	N/A	37	90	90	110
150	205	N/A	45	110	110	132
200	290	N/A	63	150	150	186
250	340	N/A	75	186	186	225
300	410	N/A	90	225	225	260
350	475	N/A	110	260	260	315
400	527	N/A	110	260	315	375
450	580	N/A	132	315	315	375
500	670	N/A	150	375	375	450
550	735	N/A	150	375	450	500
600	800	N/A	186	450	450	500
650	850	N/A	186	450	500	630
700	900	N/A	200	500	500	630
750	1000	N/A	N/A	N/A	N/A	N/A
800	1100	N/A	N/A	N/A	N/A	N/A
850	1150	N/A	225	630	630	800

Reflects Motor Standard Ratings and is not a numerical conversion.

Appendix 6

PCB PHOTOGRAPHS

VLPMEC PCB v 1.0 2005

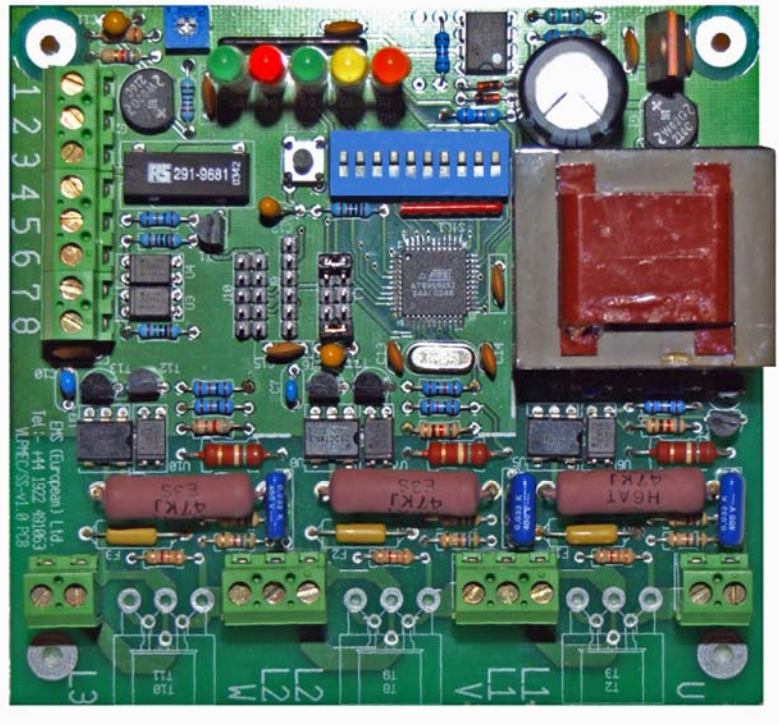

LPMEC/SS PCB v 5.5 2005

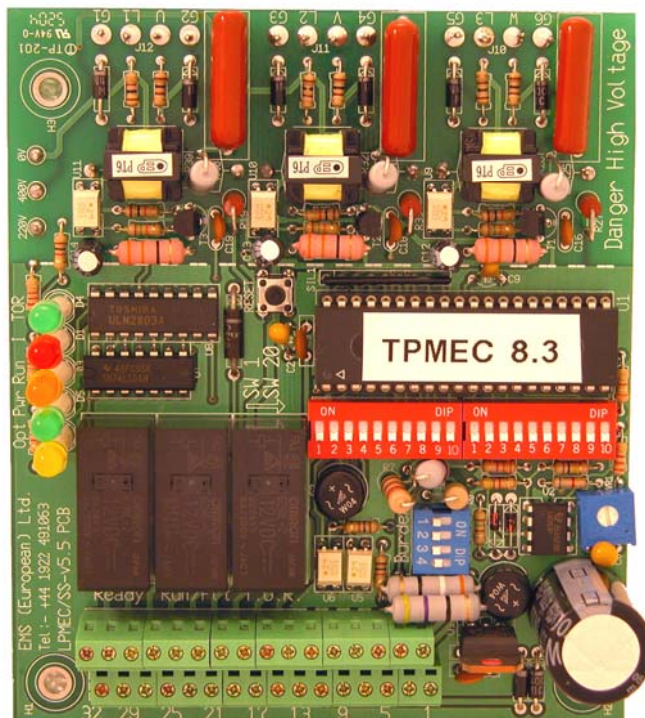

Showing the position of the bus-bar, linking on the supply inputs, (L1, L2 and L3) side of the thyristor Paks on units of 5.5kW through 37kW.

HPMEC/SS PCB v 5.5 2005

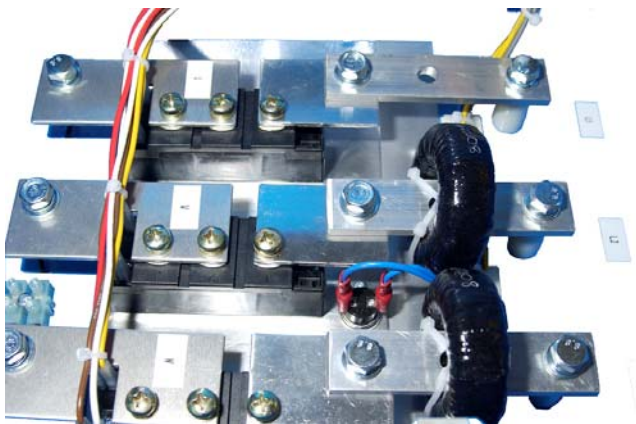
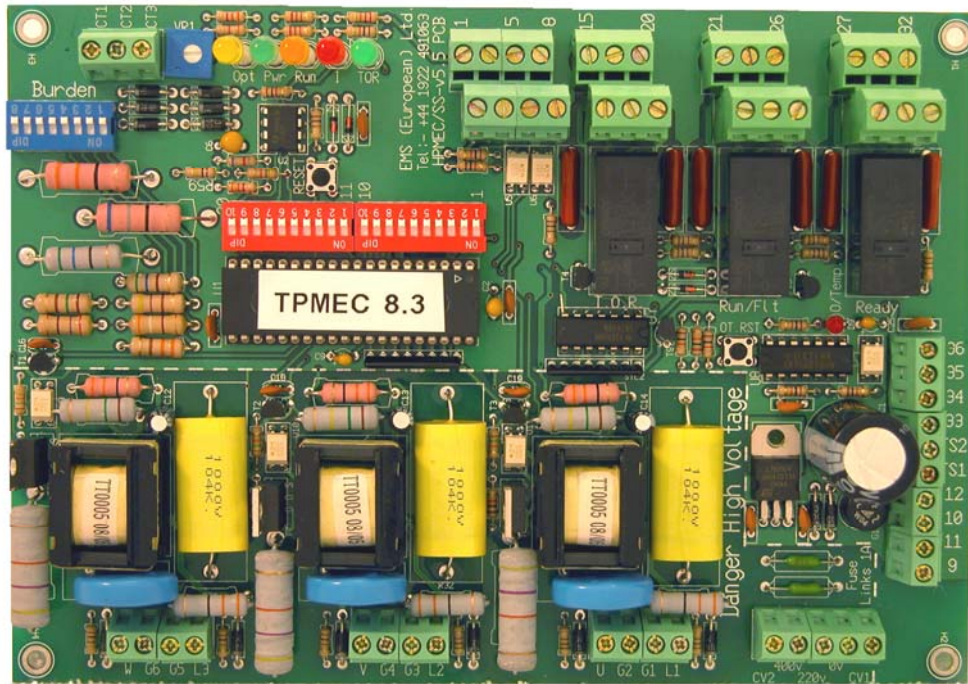

Showing the position of the bus-bar, linking on the motor feed inputs, (U, V and W) side of the thyristor Paks on units of 55kW through 800kW.

Appendix 7

PCB REPLACEMENT

The replacement of a Generation 5 PCB with a Generation 6 PCB should be a straightforward affair however some of the connections are located at different points on the PCB's and the "order" of Gate and Cathode connections on the Generation 6 HPMEC/SS PCB is different to that of its predecessor. (In this careful reference should be made to the connection table on page 18 of this Installation and Commissioning Guide).

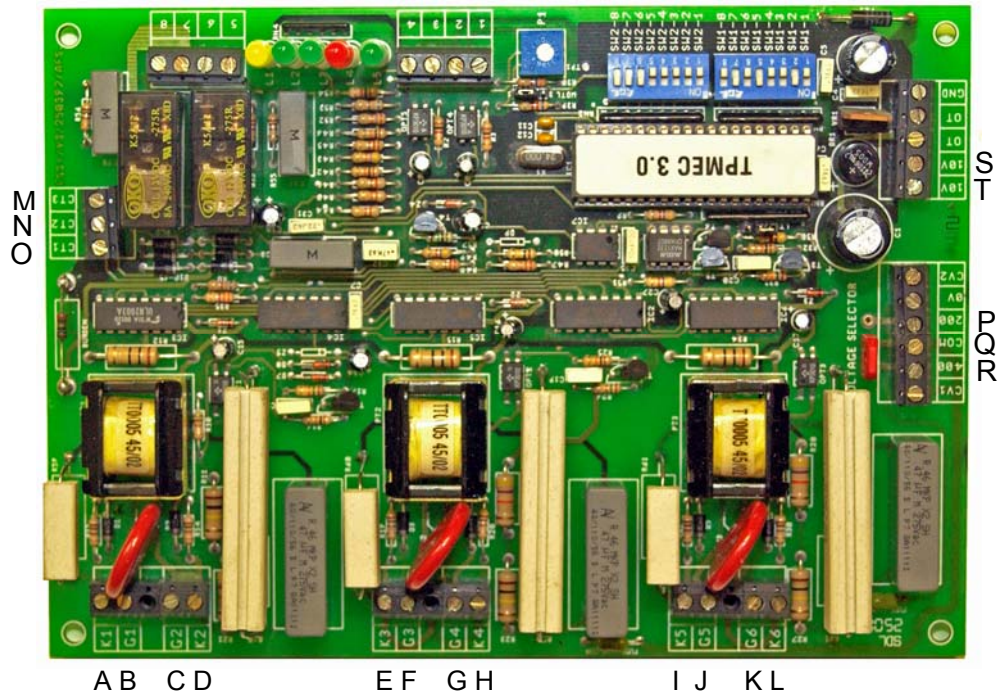

OMN

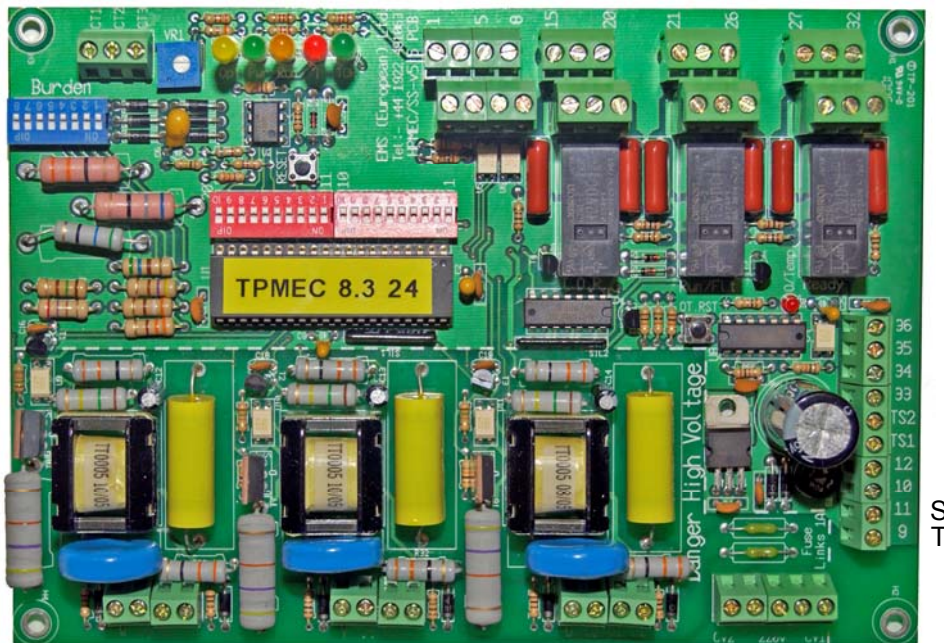

AB CD

EF GH

IJ KL

RPQ

It is unimportant which pairs of Gate and Cathode connections are on each pair output. The pictures show the colours of the various connection wires onto the two types of PCB.

When changing PCB's, always ensure that you take careful note and label the position and colour of the wires being removed so that they can be fitted back into the correct places on the new PCB

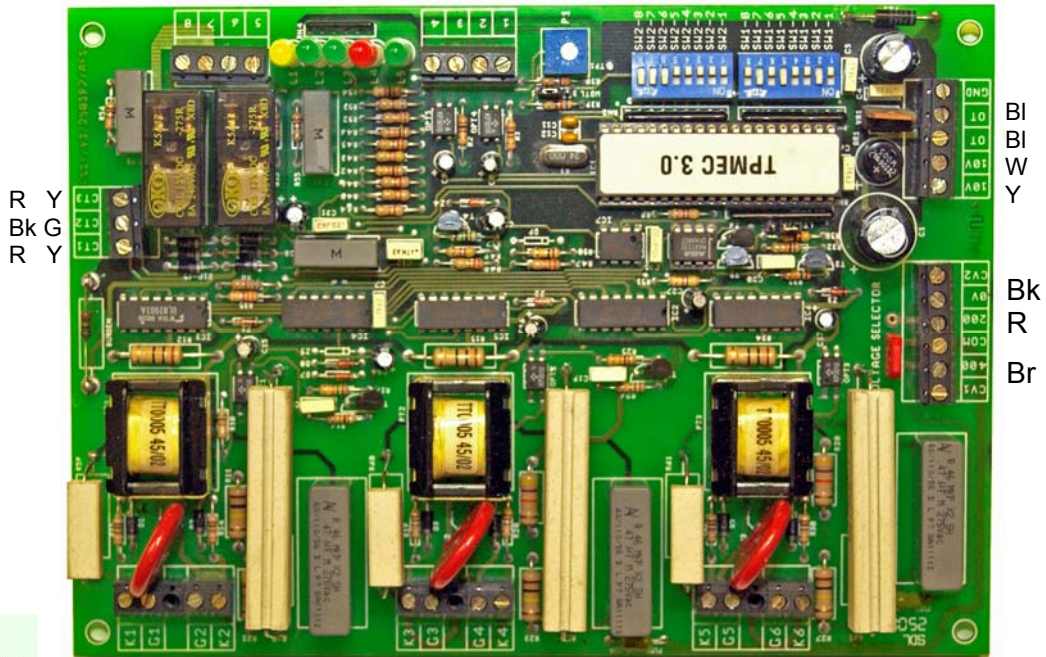

Key

- R = Red
- Y = Yellow
- G = Grey
- Br = Brown
- Bk = Black
- Bl = Blue
- W = White

R R Bk
Y Y G

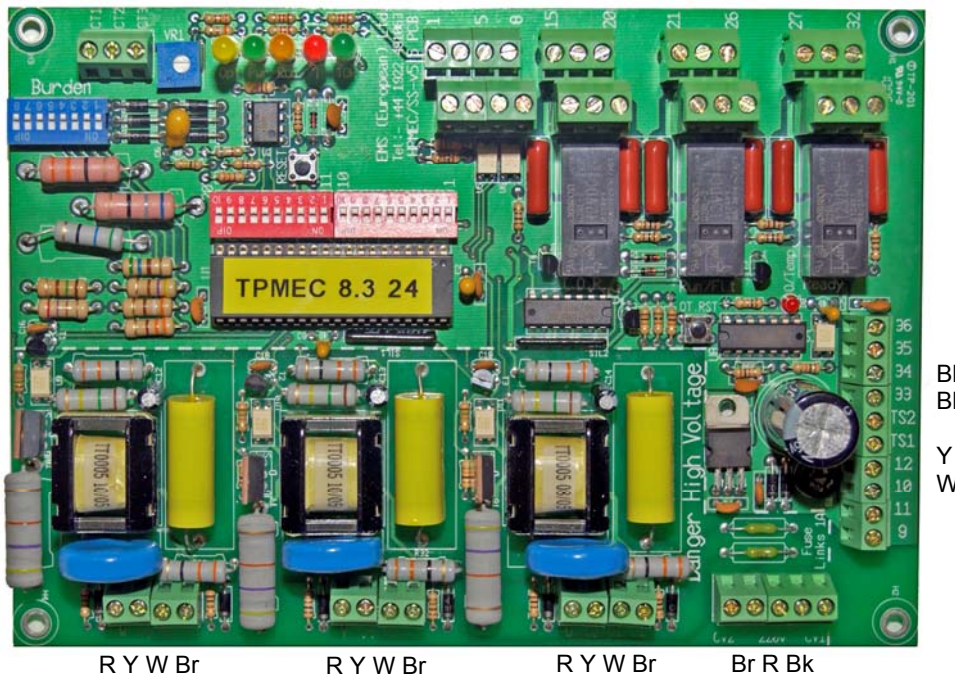

The LPMEC/SS PCB replacement should only be undertaken by a specialist facility as the thyristors on the Generation 5 systems were mounted directly into the PCB's and would require careful cleaning of the Gate and Cathode connections to ensure that the new leads from the Generation 6 PCB were properly connected. As such, should you need to replace an older LPMEC/SS PCB then please contact EMS (European) to arrange for the return of the system to the UK for the replacement to be undertaken in our manufacturing area.

LP MEC

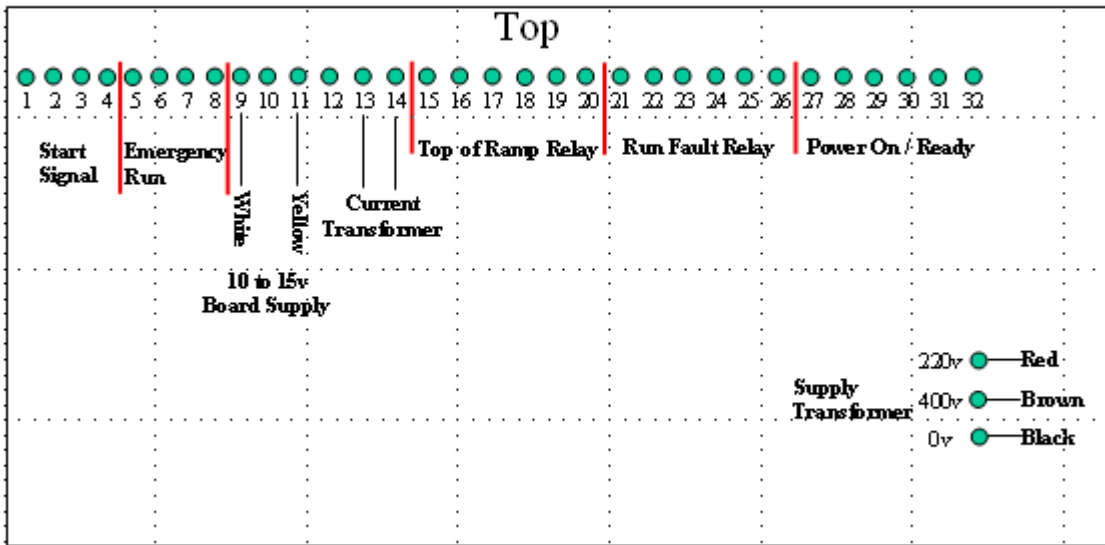

HP MEC

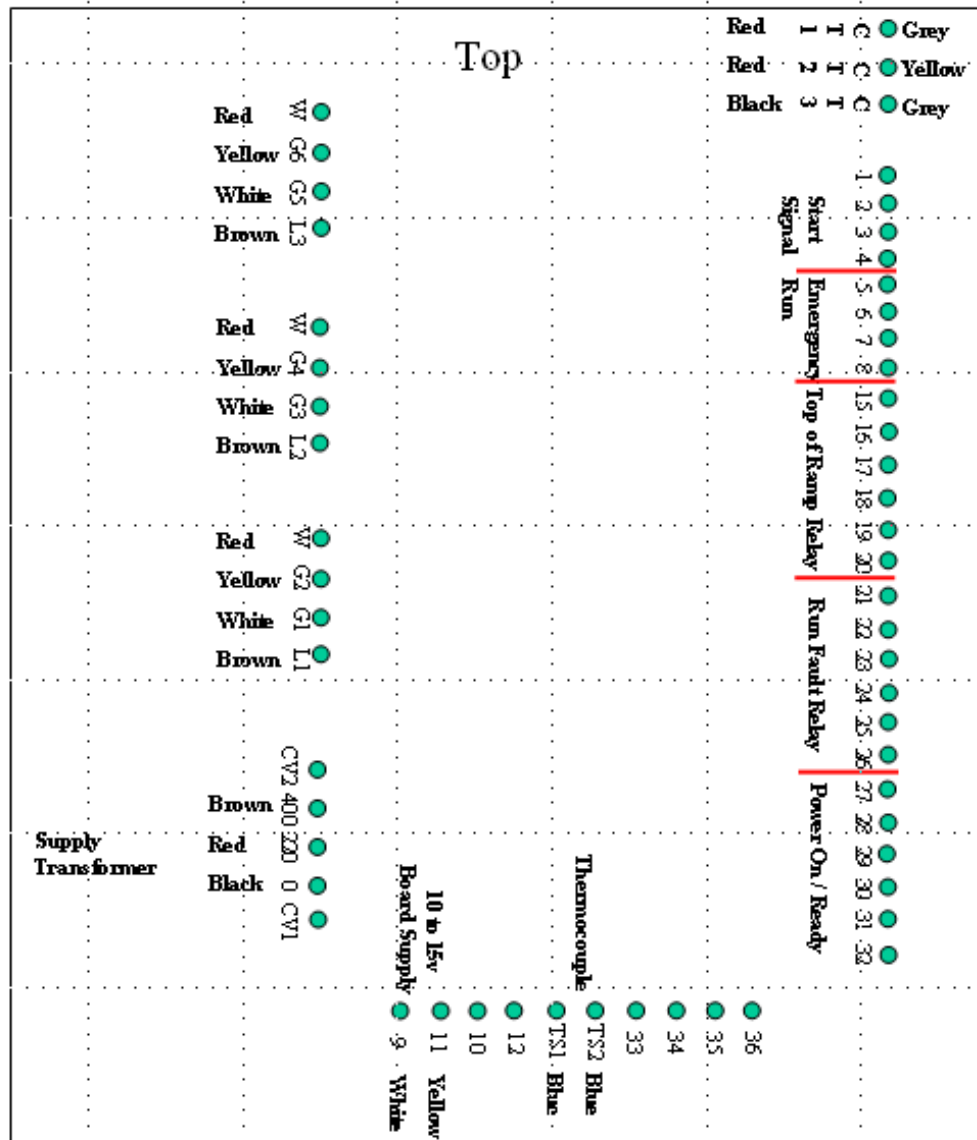

Appendix 8

DERATING CHARTS

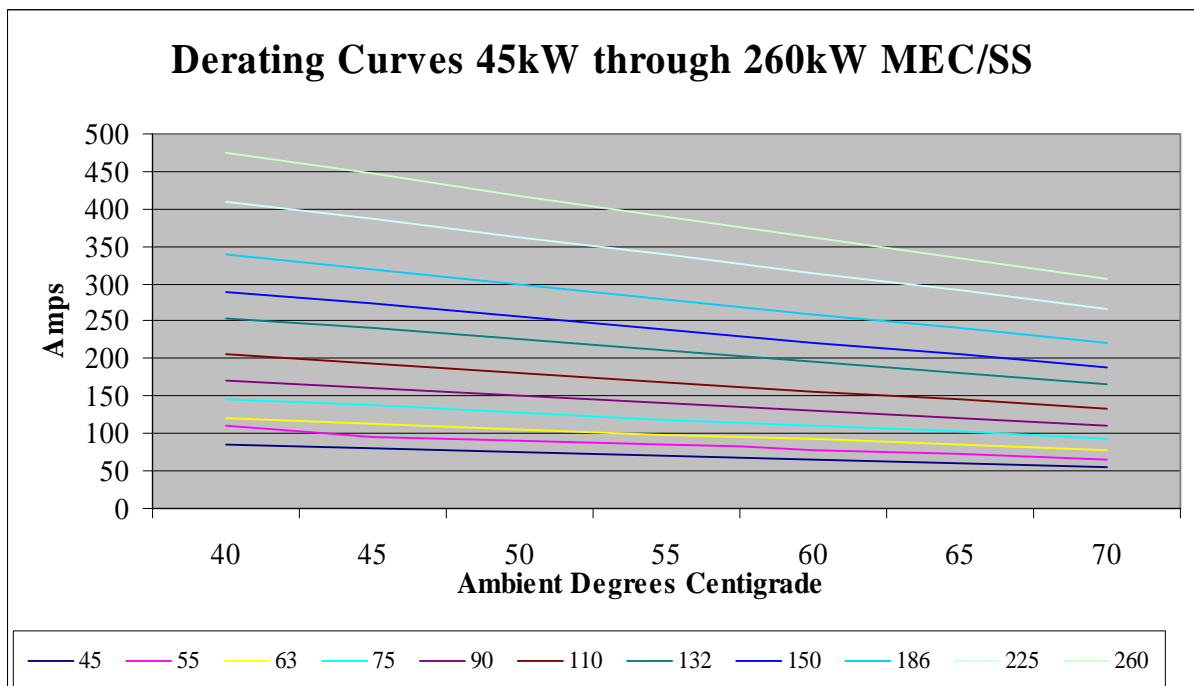
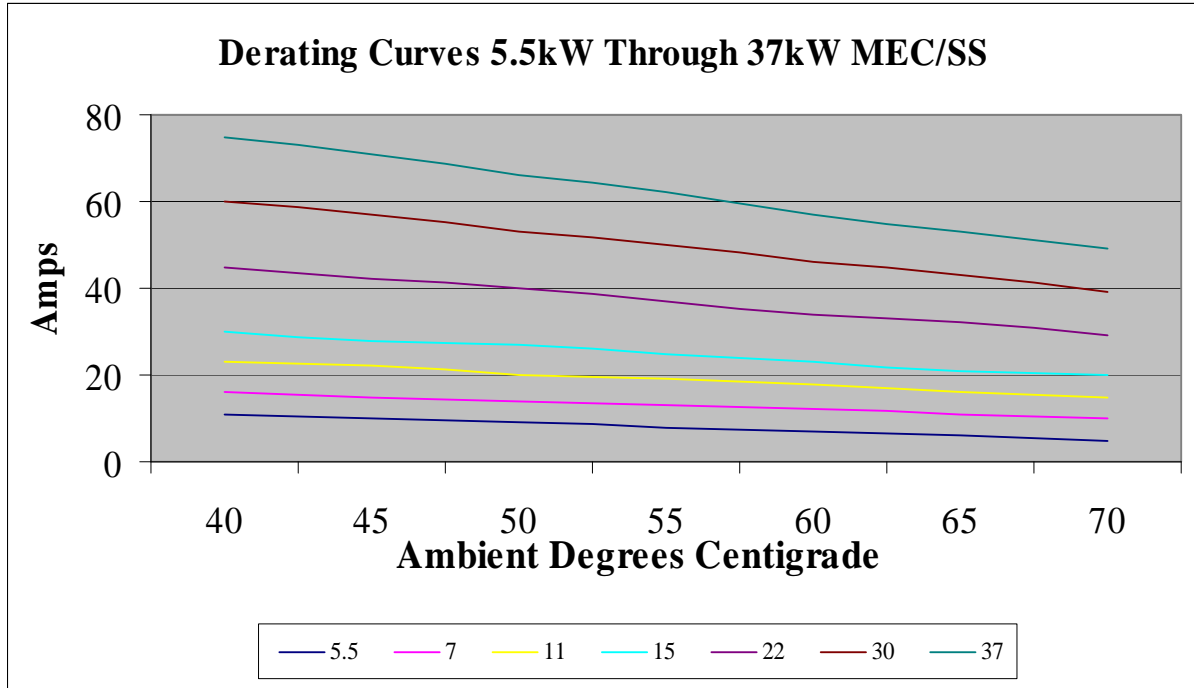

DERATING CHART

Unit Size	Temperature						
	40C	45C	50C	55C	60C	65C	70C
5kW	11A	10A	9A	8A	7A	6A	5A
8kW	16A	15A	14A	13A	12A	11A	10A
11kW	23A	22A	20A	19A	18A	16A	15A
15kW	30A	28A	27A	25A	23A	21A	20A
22kW	45A	42A	40A	37A	34A	32A	29A
30kW	60A	57A	53A	50A	46A	43A	39A
37kW	75A	71A	66A	62A	57A	53A	49A
45kW	85A	80A	75A	70A	65A	60A	55A
55kW	110A	97A	91A	85A	79A	73A	67A
63kW	120A	113A	106A	99A	92A	85A	78A
75kW	145A	137A	128A	119A	111A	103A	94A
90kW	170A	160A	150A	140A	130A	120A	110A
110kW	205A	193A	181A	169A	157A	145A	133A
132kW	255A	240A	225A	210A	196A	180A	165A
150kW	290A	273A	256A	239A	222A	205A	188A
186kW	340A	320A	300A	280A	260A	240A	220A
225kW	410A	387A	363A	339A	315A	291A	267A
260kW	475A	446A	418A	390A	362A	334A	306A
315kW	580A	547A	513A	476A	445A	411A	377A
375kW	670A	630A	591A	552A	512A	473A	433A
450kW	800A	753A	706A	659A	612A	565A	518A
500kW	900A	846A	793A	740A	687A	634A	581A
630kW	1100A	1035A	970A	905A	841A	776A	711A
800kW	1400A	1310A	1233A	1151A	1068A	986A	903A

Appendix 9

DIP SWITCH SETTINGS

Initial Recommended DIP Switch Settings by Application (Based on Software Version 8.8 and above)

Application	Off On	DIP Switch																			
		1	2	3	4	5	6	7	8	9	10	11	12	13	14	15	16	17	18	19	20
Injection Moulding	Off On	■	■	■	■	■	■	■	■	■	■	■	■	■	■	■	■	■	■	■	■
Refrigeration	Off On	■	■	■	■	■	■	■	■	■	■	■	■	■	■	■	■	■	■	■	■
Air Handling	Off On	■	■	■	■	■	■	■	■	■	■	■	■	■	■	■	■	■	■	■	■
Rock Crusher	Off On	■	■	■	■	■	■	■	■	■	■	■	■	■	■	■	■	■	■	■	■
Milling Machine	Off On	■	■	■	■	■	■	■	■	■	■	■	■	■	■	■	■	■	■	■	■
Escalator	Off On	■	■	■	■	■	■	■	■	■	■	■	■	■	■	■	■	■	■	■	■
Mechanical Press	Off On	■	■	■	■	■	■	■	■	■	■	■	■	■	■	■	■	■	■	■	■
Hydraulic Press	Off On	■	■	■	■	■	■	■	■	■	■	■	■	■	■	■	■	■	■	■	■
Air Compressor (Screw)	Off On	■	■	■	■	■	■	■	■	■	■	■	■	■	■	■	■	■	■	■	■
Air Compressor (Piston)	Off On	■	■	■	■	■	■	■	■	■	■	■	■	■	■	■	■	■	■	■	■

Do not forget to put the unit into energy saving before closing the cabinet - DIP Switch 20 to the ON Position

Appendix 10

FAULT FINDING CHARTS

